

---

# Xerox 4635 Laser Printing System Installation Planning Guide

Xerox Corporation  
701 S. Aviation Boulevard  
El Segundo, CA 90245

© 1994, 1995, 1996 by Xerox Corporation. All rights reserved.

Copyright protection claimed includes all forms and matters of copyrightable material and information now allowed by statutory or judicial law or hereinafter granted, including without limitation, material generated from the software programs which are displayed on the screen, such as icons, screen displays, looks, etc.

Printed in the United States of America

Publication number: 721P83081

Xerox® and all Xerox products mentioned in this publication are trademarks of Xerox Corporation. Products and trademarks of other companies are also acknowledged.

Changes are periodically made to this document. Changes, technical inaccuracies, and typographic errors will be corrected in subsequent editions.

This document was created on the Xerox 6085 Professional Computer System using VP software. The typeface is Optima.

---

---

## Related publications

---

The *Xerox 4635 Laser Printing System Installation Planning Guide* is part of the ten-manual reference set for your laser printing system. The entire reference set is listed in the table below. Several other related documents are also listed for your convenience. For a complete list and description of available Xerox documentation, refer to the *Xerox Documentation Catalog* (Publication number 610P17417) or call the Xerox Documentation and Software Services (XDSS) at 1-800-445-5554.

<b>Publication</b>	<b>Number</b>
<i>Xerox Dynamic Document Interface Operator Guide</i>	720P13670
<i>Xerox Dynamic Document Interface Command Summary</i>	720P13680
<i>Xerox 4635 Laser Printing System Operator Guide</i>	721P83011
<i>Xerox 4635 Laser Printing System Operations Reference</i>	721P83021
<i>Xerox 4635 Laser Printing System Sysgen Guide</i>	721P83030
<i>Xerox 4635 Laser Printing System Message Guide</i>	721P83040
<i>Xerox 4635 Laser Printing System PDL/DJDE Reference</i>	721P83050
<i>Xerox 4635 Laser Printing System Forms Creation Guide</i>	721P83060
<i>Xerox 4635 Laser Printing System Product Reference</i>	721P83071
<i>Xerox 4635 Laser Printing System Installation Planning Guide</i>	721P83081
<i>Xerox 4635 Laser Printing System Operator Command Summary Card</i>	721P83090
<i>Xerox 4635 Laser Printing System PC UI Reference</i>	721P83101
<i>Xerox Laser Printing Systems Tape Formats Manual</i>	600P86175
<i>Xerox Laser Printing Systems Standard Font Library Font User Guide</i>	600P86174
<i>Helpful Facts About Paper</i>	721P82490

---

---

## Notice

---

This publication may contain descriptions of concepts and features not currently available for your Xerox Laser Printing System. Consult your Xerox sales representative or your operating system software program description for additional information.

---

# Table of contents

Related publications	iii
Notice	iv
<b>Introduction</b>	ix
What this guide contains	ix
4635 Laser Printing System Document Set	x
Responsibilities	xii
Xerox or Rank Xerox responsibilities	xii
Customer responsibilities	xiii
Installation planning checklist	xiv
<b>1. LPS overview</b>	1-1
The 4635 LPS	1-1
Base components	1-2
System controller components	1-2
4635 printer and 4635MX printer components	1-4
Magnetic Ink Character Recognition (MICR)	1-6
<b>2. LPS options</b>	2-1
System controller options	2-1
Interface options	2-1
Online interfaces	2-1
Offline interfaces	2-1
HIP-accessed interfaces	2-2
Expanded system disk memory	2-3
Enhanced graphics ink and font memory (EGIFM)	2-3
Floppy disk drive	2-3
Printer options	2-3
Feeder stacker	2-3
Bypass transport	2-3
Input enablement device	2-4
7x10 enablement kit	2-4
Bar code device	2-4
Printer configurations	2-5
Graphics	2-7
Enhanced advanced image processor (EAIPX)	2-7

	Graphic scanning	2-7
	Xerox 7650 Pro Imager	2-7
	Raster Image Processor	2-7
	Host-resident software packages	2-8
	Xerox Pen Plotter Interface/XDGI	2-8
	Host Forms Description Language	2-8
	Xerox Printer Access Facility	2-8
<b>3. Preinstallation</b>		3-1
	LPS space and delivery requirements	3-1
	System controller	3-2
	Printer	3-3
	Space planning guidelines	3-7
	Clearance space requirements	3-7
	Shared space	3-7
	Cable lengths	3-10
	Cable locations	3-11
	Efficiency of use	3-11
	Delivery access requirements	3-12
	Environmental/electrical requirements	3-15
	4635 LPS power receptacle requirements	3-16
	50 Hz WYE printer outlet voltages	3-17
	50 Hz DELTA printer outlet voltages	3-18
	50 Hz system controller and peripheral cabinet power cord configurations	3-19
	60 Hz printer outlet voltages	3-19
	60 Hz system power cord configurations	3-20
	Finishing and feeding equipment	3-21
	Interface requirements	3-21
	Channel-attached	3-21
	Third party connections	3-21
	Training	3-22
	Operator training	3-22
	Systems training	3-22
	Ordering supplied for installation	3-23
	Fonts	3-23
	Paper	3-24
	Dry ink (toner)	3-25
	Fuser agent	3-25
	Developer	3-25
	Tapes	3-25

	Space planning templates	3-26
<b>4. Installation</b>		4-1
	The installation process	4-1
	Installation responsibilities	4-1
	Xerox or Rank Xerox responsibilities	4-1
	Customer responsibilities	4-2
	Documentation and software kits	4-2
	Documentation	4-2
	Software kits	4-2
<b>5. Postinstallation</b>		5-1
	Xerox support services	5-1
	Xerox Customer Support Center	5-1
	Customer Service Support Center	5-2
	Xerox Font Center	5-3
	<i>Xerox Customer Documentation Catalog</i>	5-3
	Xerox Documentation and Software Services (XDSS)	5-3
	Xerox Supplies Order Service	5-4
	Routine maintenance	5-5
	Meter reading and reporting	5-5
	Identifying new applications	5-5
	Consumable supplies table	5-6
<b>Glossary</b>		GLOSSARY-1
<b>Index</b>		INDEX-1





Soon your new Xerox 4635 Laser Printing System (LPS) will be delivered. As with any new equipment, certain things must be in place before the equipment can be installed.

The *Xerox 4635 Laser Printing System Installation Planning Guide* (IPG) is designed to help you answer these questions and to help you, as the coordinator of the installation for your company, accomplish the preinstallation requirements, as well as the ongoing activities after the laser printing system is installed.

---

## What this guide contains

---

The *Xerox 4635 Laser Printing System Installation Planning Guide* provides you with the necessary information to ensure a successful installation, such as:

- LPS basic components and options
- Tasks that must be accomplished before installation
- Responsibilities for each task
- Supplies and fonts that must be ordered
- Delivery requirements
- Postinstallation activities.

The *Xerox 4635 LPS Installation Planning Guide* is divided into five chapters and an appendix as follows:

**Chapter 1:** *LPS overview.* Provides an overview of the Xerox 4635 Laser Printing System. Describes the basic system controller and printer components.

**Chapter 2:** *LPS options.* Describes the system controller, printer, graphic, and host-resident software options available for the laser printing system.

**Chapter 3:** *Preinstallation.* Provides information on configuration requirements, environmental and electrical requirements, cabling, supplies, and access requirements. Space planning templates and a grid are provided at the end of the chapter.

**Chapter 4:** *Installation.* Describes the installation process, reviews Xerox or Rank Xerox and site responsibilities, and lists the components of the documentation and software kits that are delivered with the system.

**Chapter 5:** *Postinstallation.* Describes Xerox or Rank Xerox support services, routine maintenance, meter reading and reporting, and supplies activities. Also provides a consumables table and a checklist for ordering supplies.

A glossary and an index are provided at the back of the manual.

The IPG is one of many manuals designed to help you receive maximum benefit from your 4635 LPS. You receive the IPG first to help you prepare for your system's installation. To help you

select the appropriate document for your needs, the following section identifies the documents in the set and describes the information contained in each.

---

## 4635 Laser Printing System Document Set

---

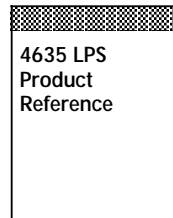

- Product overview
- Hardware and software
- LPS connections
- User considerations
- LPS comparisons

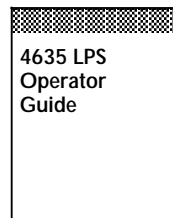

- System overview
- PC UI procedures
- Paper facts and procedures
- Operating procedures
- Maintenance
- Problem solving
- Supplies
- Meter reading and reporting

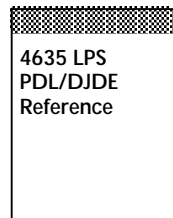

- Print Description Language components and processes
- Input processing functions
- Output processing functions
- PDL/DJDE command summary
- Page formatting guidelines
- Character code assignment tables
- PDL/DJDE programming information with step-by-step instructions

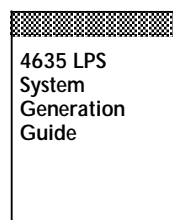

- Configuration options
- Commands
- OSS software installation, upgrade, and modification procedures

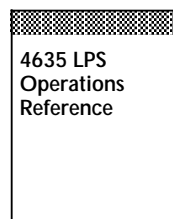

- Command syntax for operator and system administrator procedures
- LPS defaults
- LPS resources
- Command summaries
- Communication and graphics on the LPS
- Command files

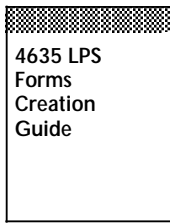

- Basic concepts for creating forms
- Coding and compiling for LPS Forms Description Language
- Sample form setup command sets
- Tips for successful forms creation

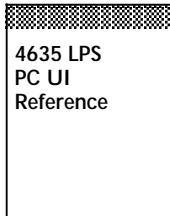

- PC UI procedures
- Hierarchy of PC UI windows

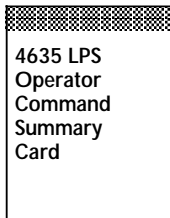

- Provides a quick reference of commonly-used operator commands.

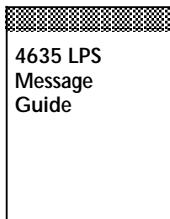

- OSS and other messages
- Meaning and recovery procedures

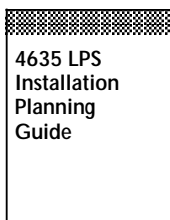

- Pre-installation site preparation
- Supplies and font ordering
- Documentation and training
- Post-installation requirements

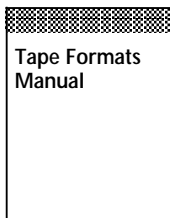

- Characteristics of different formats
- File organization
- Data formats
- Carriage control conventions

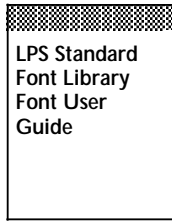

- Font naming conventions
- Listing of standard fonts
- Data sheets
- Glossary to typography terminology

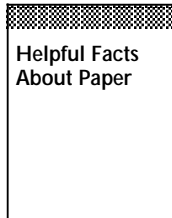

- Selection and guidelines
- Storage and handling
- Specifications for different printers

---

## Responsibilities

---

A successful installation depends upon both Xerox or Rank Xerox and you. The sections that follow describe your site responsibilities and the responsibilities Xerox or Rank Xerox has to you. You will see that some areas overlap and become joint responsibilities.

**Note:** Rank Xerox Ltd. is the European affiliate of the Xerox Corporation, which serves the United Kingdom, all European countries, and Australia.

### Xerox or Rank Xerox responsibilities

---

Xerox or Rank Xerox responsibilities prior to, during, and after installation of the LPS are to:

- |                       |  |
|-----------------------|--|
| <b>Site selection</b> | <ul style="list-style-type: none"> <li>• Assist in site selection</li> <li>• Inspect and approve the site</li> </ul>   |
| <b>Installation</b>   | <ul style="list-style-type: none"> <li>• Schedule the delivery of your laser printing system</li> <li>• Monitor installation activities</li> <li>• Assist you in ordering supplies and fonts</li> <li>• Install the LPS</li> </ul>   |
| <b>Training</b>       | <ul style="list-style-type: none"> <li>• Provide standard operator training</li> <li>• Assist in determining system and training needs</li> <li>• Assist in scheduling system and user training</li> </ul>   |
| <b>Support</b>        | <ul style="list-style-type: none"> <li>• Provide assistance and information, as needed, in the areas of:             <ul style="list-style-type: none"> <li>— Software capabilities</li> <li>— Operations</li> <li>— Applications and forms development</li> <li>— Interface capabilities</li> </ul> </li> </ul> |

- Service**
- Review preventative maintenance schedules and service call procedures
  - Provide ongoing system maintenance
  - Resolve hardware and software problems.

## Customer responsibilities

---

Your responsibilities prior to, during, and after installation of the LPS are to:

- Identify the primary interface with Xerox.
- Select and prepare the site for LPS installation (including adequate power and air conditioning).
- Obtain the necessary interfaces, cables, transceivers, phone lines, and so forth, if connecting to other equipment.
- Plan for and schedule installation activities.
- Monitor progress for a successful installation.
- Order and maintain supplies.
- Work with your Xerox or Rank Xerox representatives to determine requirements for initial applications.
- Work with representatives from the company you have purchased any additional equipment from (such as feeders or finishers).

**Note:** Be sure that your system specialists are familiar with the operating system software specific to your LPS; operating system software is not the same for all laser printing systems. If your system specialists are familiar with one of these operating systems and you are converting to or adding another, they should learn the differences.

- Select operators and system specialists, and schedule their training.

**Note:** In a mixed environment where there are a variety of printing systems, discuss print quality differences with your Xerox or Rank Xerox service representative.

**Training** Operator training is conducted at your site shortly after the LPS has been installed. Operators receive hands-on instruction on printing jobs, maintenance, and problem solving.

Xerox offers a number of workshops and self-paced courses that teach advanced skills, including Advanced Customer Training (ACT). Contact your sales representative for additional information about these courses, or call Xerox Customer Education at 1-800-445-5554. (Refer to the "Documentation and training" section of chapter 3, "Preinstallation.")

- Personnel** One or more people need to be assigned the following routine LPS tasks:
- Preventative maintenance and cleaning
  - Meter reading and reporting

- Placing service calls for hardware problems and applications-related issues
- Identifying and implementing new applications
- Ordering additional fonts
- Ordering supplies.

Refer to the "Postinstallation" chapter in this guide for information on these activities.

---

## Installation planning checklist

---

To aid you in LPS installation planning, an installation planning checklist is provided. Refer to table 0-1, which summarizes the tasks that must be performed and when in the installation process they should occur.

Use the checklist as a guide for ensuring successful installation of the LPS. Should you have any questions, please contact your sales representative or local Xerox or Rank Xerox office.

- The **Week** column shows the approximate time an activity should occur. The weeks shown relate to the installation date. For example, -4 is four weeks prior to installation.
- The **Reference** column lists the chapter in this manual which provides detailed information for that activity.

**Note:** The time frames are intended to serve only as guidelines. Consult your suppliers to determine exact delivery lead times.

Table 0-1. Installation planning checklist

Week	Activity	Reference	Responsibility	Date completed
-5	Sign up for Xerox Documentation and Software Services	XDSS order form	Customer	_____
-4	Order additional manuals, if needed	p. iii, chapter 5	Customer	_____
	Schedule LPS delivery		Xerox	_____
	Identify system specialist and schedule training	Introduction	Customer/Xerox	_____
	Select site	Chapter 3	Customer/Xerox	_____
	Prepare site	Chapter 3	Customer	_____
	— Space requirements			_____
	— Electrical requirements			_____
	— Cabling			_____
	— Environment requirements (temperature, humidity, heat dissipation)			_____
-3	Call the Xerox Font Center to request LPS font samples	Chapter 3, 5	Customer	_____
	Order custom fonts and logos	Chapter 5	Customer	_____
-2	Train user systems specialists		Xerox	_____
	Schedule operator training	Chapter 3	Customer/Xerox	_____
	Order licensed fonts and signatures	Chapter 3	Customer	_____
	Order consumable supplies	Chapter 3	Customer/Xerox	_____
	Minimum requirements needed for installation:			
	— Paper (2 cartons)			
	— Developer (1 carton)			
	— Fuser agent (2 cartons)			
	— Dry ink (1 carton)			
	<b>Note:</b> These are the minimum supplies necessary for installation. You should have at least one more carton of each item on hand at all times.			
-1	Inspect and approve site		Xerox	_____

Table 0-1. **Installation planning checklist** (continued)

Week	Activity	Reference	Responsibility	Date completed
<b>Installation</b>	Ensure that needed supplies are available	Chapter 5	Customer	_____
	Install LPS	Chapter 4	Xerox	_____
	Have system specialist on hand		Customer	_____
	Install primary application		Customer/Xerox	_____
	Have test jobs available, if desired		Customer	_____
	Have operators available for training		Customer	_____
	Train operators		Xerox	_____
	Check documentation kit		Customer	_____
	Review preventative maintenance schedules and service call procedures		Xerox	_____
<b>Post-installation</b>	Provide ongoing system maintenance	Chapter 5	Customer/Xerox	_____
	Establish supplies maintenance procedures		Customer	_____
	Identify additional applications	Chapter 5	Customer/Xerox	_____



This chapter provides a brief overview of the Xerox 4635 Laser Printing System (LPS).

---

## The 4635 LPS

---

The Xerox 4635 Laser Printing System is a versatile, high-performance laser printing system that processes and prints data from a variety of sources. It enables host mainframe computers and network-connected devices (such as workstations and graphic scanners) to produce publications and other documents, incorporating graphics, forms, logos, signatures, and a variety of fonts.

The computer processing and memory features built into the 4635 LPS eliminate the need for a host computer to store and manage forms, fonts, logos, and other document resources.

Data is printed at a rate of up to 135 pages per minute, or up to 154 pages per minute with the optional 7X10 input enablement kit. A variety of fonts ranging in size from 3 points to 36 points, in all four orientations (portrait, inverse portrait, landscape, inverse landscape), and many publishing typefaces are available to meet your printing requirements. In addition to the standard set of fonts that is delivered with the LPS, special or customized fonts can be developed by the Xerox Font Center.

Figure 1-1 shows one of the 4635 configuration options. For information on the various 4635 LPS printer configuration options, refer to the "Printer configurations" section in the "LPS options" chapter.

Figure 1-1. 4635 Laser Printing System

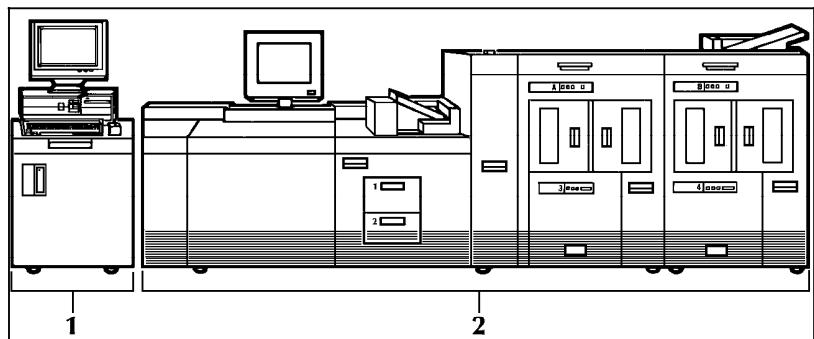

- 1 System controller
- 2 Printer

## Base components

---

This section briefly describes the standard features of the 4635 LPS system controller and printer. Optional LPS features are described in chapter 2, "LPS options."

The LPS consists of two base components:

- System controller
- Printer.

## System controller components

---

The system controller is the part of the 4635 LPS that allows you to interact with the printer. Use the personal computer user interface (PC UI) to enter commands and select options which control the operation of the printer. The parts of the system controller are shown in figure 1-2 below.

Figure 1-2. **System controller shown with PC UI**

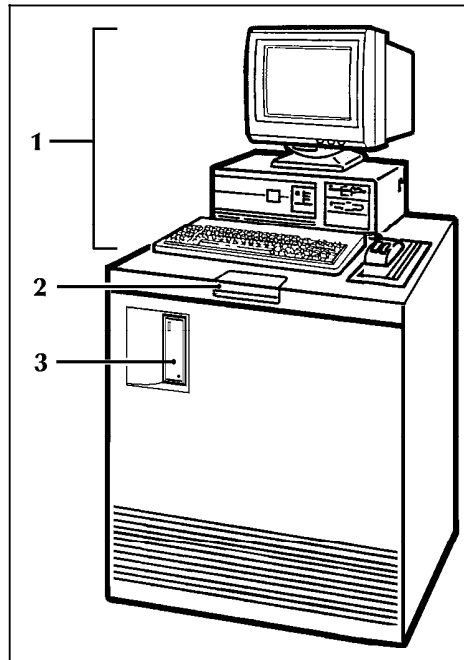

- 1 PC UI (or terminal)
- 2 Operator control panel
- 3 1/4-inch cartridge tape drive

**PC UI** The PC User Interface (PC UI) is a Pentium-base processor PC with at least 100-megabyte hard disk, mouse pointing device, 3.5-inch floppy disk drive, multinational keyboard, and 14-inch color monitor. You issue commands and control printer functions primarily through color windows and icons displayed on the PC UI monitor.

Figure 1-3. **PC UI**

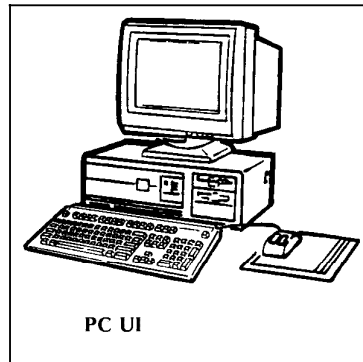

**Note:** Several PC UI types are available. Your PC UI may look different from the one illustrated in figure 1-3.

**1/4-inch cartridge tape drive**

The 1/4-inch cartridge tape drive, also called the QIC, is located in the front panel of the system controller. It is used for system generation (sysgen), disk save and restore (DSR), and file loading/backup for online systems. The 1/4-inch cartridge tape drive is not an input source for print jobs.

**System disk**

One 651 MB unformatted system disk is provided with the 4635 system controller as a standard feature. The system disk is located inside the system controller and stores the LPS operating system software, fonts, forms, and general user files.

**Operator control panel**

The system controller is powered on or off, booted, and switched between local and remote operation using the buttons on this panel, as shown in figure 1-4.

Figure 1-4. **Operator control panel**

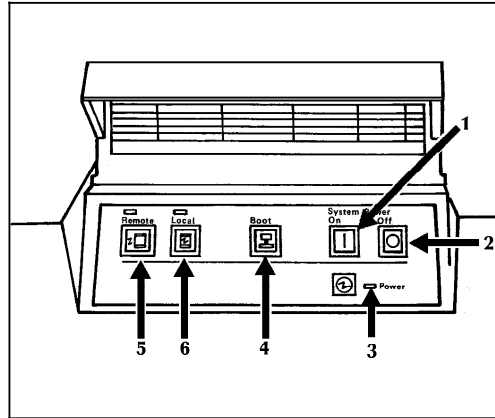

- |                      |                               |
|----------------------|-------------------------------|
| 1 Power On switch    | 4 Boot switch                 |
| 2 Power Off switch   | 5 Remote switch and indicator |
| 3 Power On indicator | 6 Local switch and indicator  |

**4635 printer and 4635MX printer components**

The printer is the part of the 4635 LPS and the 4635MX LPS that processes the electronic data and images received from the system controller and produces the printed report. The parts of the printer are shown in figure 1-5 below.

Figure 1-5. **4635 and 4635MX printer**

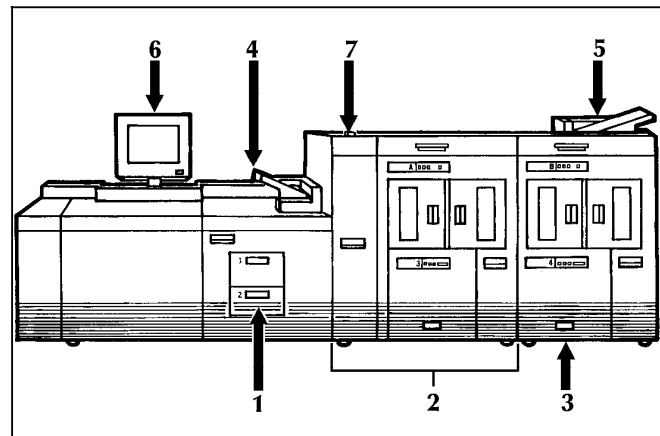

- |                                  |                           |
|----------------------------------|---------------------------|
| 1 Processor feeder trays         | 4 Sample tray             |
| 2 Inverter feeder/stacker module | 5 Purge tray              |
| 3 Feeder/stacker module          | 6 Printer control console |
|                                  | 7 Attention light         |

<b>Processor feeder trays</b>	<p>Two processor feeder trays are located in the main part of the printer:</p> <ul style="list-style-type: none"><li>• The main tray (tray 1) holds up to 1100 sheets of 20 pound/75 gsm (grams per square meter) paper.</li><li>• The auxiliary tray (tray 2) holds up to 600 sheets of 20 pound/75 gsm paper.</li></ul>
<b>Inverter</b>	<p>The inverter is part of the inverter feeder/stacker module. It allows for proper collation of the print job. It also directs printed output to the sample tray, when required.</p>
<b>High-capacity feeder</b>	<p>There is a high-capacity feeder (HCF) tray located in the bottom half of each feeder/stacker module.</p> <p>Each HCF tray can hold up to 2600 sheets of 20 pound/75 gsm paper.</p>
<b>High-capacity stacker</b>	<p>There is a high-capacity stacker (HCS) bin located in the top half of each feeder/stacker module.</p> <p>Each HCS bin can hold up to 2500 sheets of 20 pound/75 gsm paper. Paper can be stacked directly onto the HCS pallet or into a specially-designed container. Stacking capacity is approximately 100 to 150 sheets less when stacking into a container.</p>
<b>Sample tray</b>	<p>The sample tray located on top of the printer holds up to 100 sheets of paper. Output such as transparencies and sample prints of fonts or forms are sent to the sample tray.</p>
<b>Purge tray</b>	<p>The purge tray is located on top of the feeder/stacker module. Aborted sheets (for example, damaged sheets or sheets cleared after a paper jam) are sent to this tray. The purge tray can hold up to 100 sheets of paper.</p>
<b>Printer control console</b>	<p>The printer control console is the color monitor located on top of the printer. It contains message areas and graphic displays that alert you to paper jams and other fault conditions, such as low toner. The printer control console also contains buttons which allow you to control certain functions of the printer (for example, continuing an interrupted job) without returning to the PC UI or terminal.</p>
<b>Attention light</b>	<p>An attention light is mounted on top of the inverter module. The attention light signals when the printer requires operator attention.</p>
<b>Attention alarm</b>	<p>The attention alarm sounds when the printer requires operator attention. The alarm may be disabled by the operator.</p>

## Magnetic Ink Character Recognition (MICR)

The 4635MX Laser Printing System (LPS) produces a MICR line on negotiable and turnaround documents such as checks and bills. Figure 1-6 shows an example of a MICR line.

Figure 1-6. MICR line

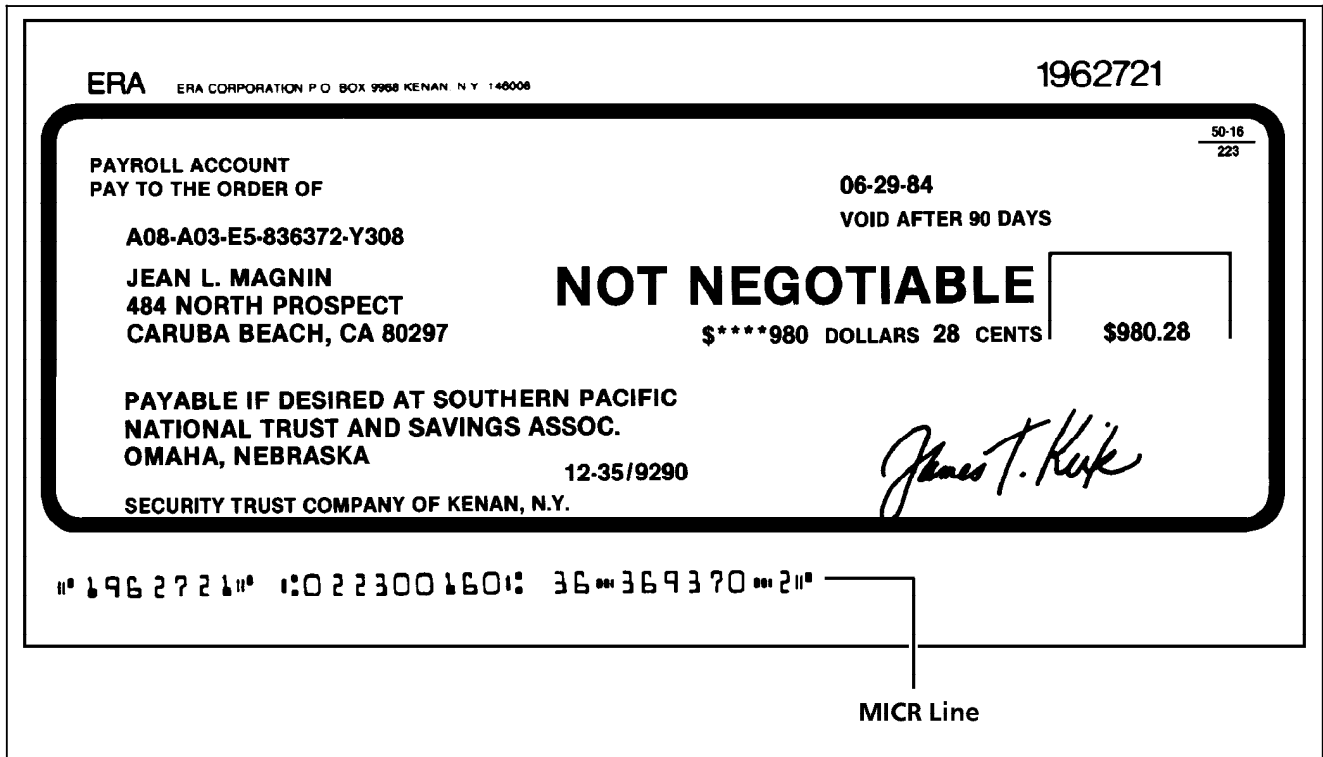

There are many options available for your Xerox 4635 Laser Printing System (LPS) which offer a wide range of enhanced printing and communications capabilities. This chapter provides a brief overview of the options for the following:

- System controller options
- Printer options
- Printer configurations
- Graphics
- Host resident software packages.

For detailed information regarding these options, contact your customer support representative.

---

## System controller options

---

The following interface and system disk options are available for your Xerox 4635 Laser Printing System (LPS) system controller.

---

## Interface options

---

Your laser printing system may be configured for either the online interface, the offline interface, or both (switchable). HIP (host interface processor)-accessed interfaces are also available.

### Online interface

---

The online (channel-attached) interface receives input directly from any environment that supports the IBM 3211 and 4245 host systems.

### Offline interfaces

---

The offline interface is an excellent alternative or addition to an online operation. It supports:

- 9-track magnetic tapes
- 18-track cartridge tapes.

The 9-track magnetic and 18-track cartridge tape drives are housed in a peripheral cabinet, as shown in figure 2-1.

Figure 2-1. Peripheral cabinet with tape drives

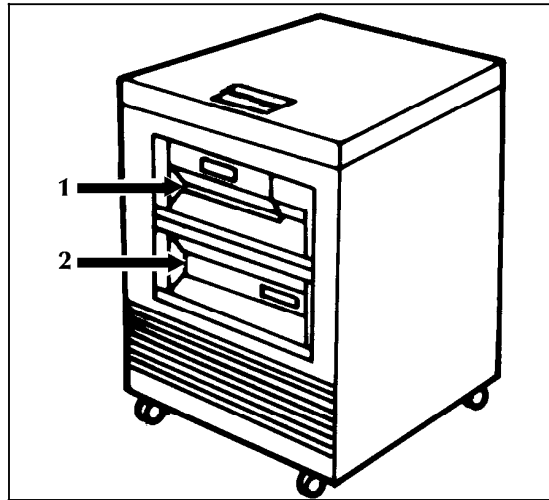

- 1 9-track magnetic tape drive
- 2 18-track cartridge tape drive

#### 9-track magnetic tape drive

The 9-track (1600 and 6250 bpi) magnetic tape drive is an alternative or additional offline capability to the 18-track cartridge tape drive. It is a source for print data such as forms, graphics, and variable data. System software and diagnostics can also be input from the 9-track magnetic tape drive. This tape drive can write data to tape for system backup or for printing at a later time.

#### 18/36 track cartridge tape drive

Like the 9-track magnetic tape drive, the front-loading 18/36 track cartridge tape drive is a source for inputting forms, graphics, variable data, and other files to the 4635 LPS system controller for printing or storage. The 18/36 track cartridge tape drive reads and writes IBM-compatible and ANSI-compatible 0.5 inch tape in the 3480 or 3490 data format.

#### HIP-accessed interfaces

---

The Host Interface Processor (HIP) software supports communication in the following environments:

- Xerox Network Systems (XNS) (Ethernet interface)
- Xerox Print Access Facility (XPAF)
- Xerox Print Service Manager (XPSM)

**XNS** Xerox Network Systems (XNS) enables communication between devices such as workstations and graphic stations and the LPS through a network. Ethernet is the physical connection for the network, and Interpress is the page description language used in packaging files for transmission over the network to the LPS.

**XPAF** Xerox Print Access Facility (XPAF) is a host-resident product that retrieves data streams from JES and prepares them for printing on a Xerox laser printer.



---

**XPSM** Xerox Print Service Manager (XPSM) is a printing solution for production printing environments. It consists of both client and server sites.

---

## Expanded system disk memory

---

The 4635 LPS has one standard 650 MB system disk with optional expansion up to 2,600 MB in 650 MB increments.

---

## Enhanced graphics ink and font memory (EGIFM)

---

The 4635 LPS has a standard 64 Mbits of font/graphic memory that can be expanded to 256 Mbits.

---

## Floppy disk drive

---

When installed, the optional floppy disk drive is located in the system controller, to the right of the 1/4 inch cartridge tape drive. It allows you to transfer files between a floppy disk and the system controller's hard disk. Therefore, it provides an alternative way for backing up and restoring system controller rigid disk files.

---

## Printer options

---

---

### Feeder stacker

---

The 4635 LPS has an Inverter Feeder Stacker, and up to three optional feeder stackers.

Refer to the section "Printer components" in the "LPS overview" chapter for information on the feeder stackers.

---

### Bypass transport

---

The ability to add finishers to your 4635 LPS is made possible by the Bypass Transport option. Finishers increase your production capabilities by providing a wide range of finishing choices, such as stitching, shrink wrapping, and so on.

Connected to the feeder/stacker, the bypass transport allows finishers to interface directly with your 4635 LPS. The bypass transport meets the Xerox Document Feeding and Finishing Architecture (DFA) Level 1 specifications.

Figure 2-2 shows the 4635 LPS with the optional bypass transport and the paper output and input locations.

Figure 2-2. **4635 LPS with optional bypass transport and input enablement device**

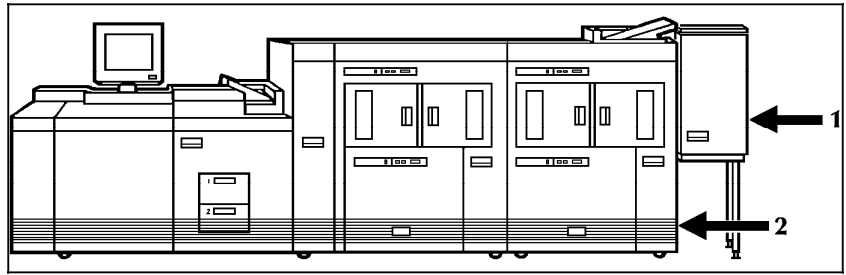

- 1 Bypass transport paper output location
- 2 Input enablement device paper input location

## Input enablement device

Adding feeders to your 4635 LPS is made possible by the input enablement device option. Located on the right side of the feeder/stacker, it allows your 4635 LPS to support and interface directly with feeders. Figure 2-2 points to the location of the input enablement device.

## 7X10 enablement kit

The 7 X 10 input enablement kit allows your 4635 to print on 7 X 10 inch paper size.

## Bar code device

The bar code feature allows processing of bar code data streams with the ability to cross-check the system UI, the controller and the printer. This cross-checking ensures that any bar code sheets printed have been accounted for by each component of the system.

Figure 2-3 shows the 4635 LPS with the optional bar code device.

Figure 2-3. **4635 LPS with optional bar code device**

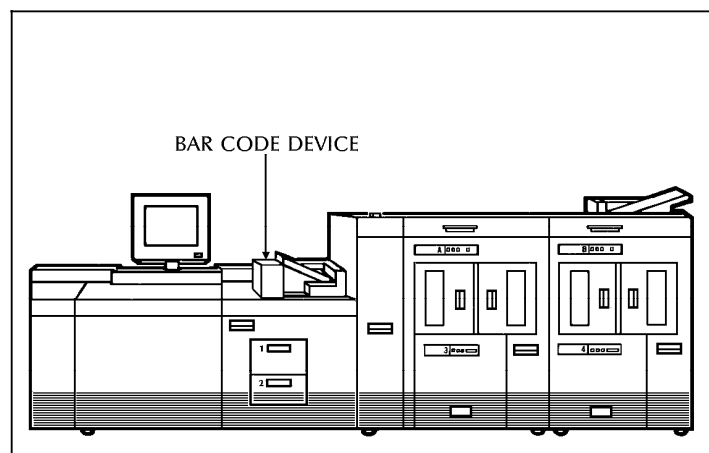

## Printer configurations

The 4635 LPS is available in the following five configurations:

1. Printer + Inverter Feeder Stacker + Feeder Stacker
2. Printer + Inverter Feeder Stacker + Feeder Stacker + Bypass Transport
3. Printer + Inverter Feeder Stacker + Feeder Stacker + Feeder Stacker
4. Printer + Inverter Feeder Stacker + Feeder Stacker + Feeder Stacker + Bypass Transport
5. Printer + Inverter Feeder Stacker + Feeder Stacker + Feeder Stacker + Feeder Stacker

Each of these configurations can have the following printer options:

- 7X10 enablement kit
- Bar code device
- Input enablement device

**Notes:**

- The input enablement device is not available on the last configuration: Printer + Inverter Feeder Stacker + three Feeder Stackers.
- Each of the configurations and options above is available with the 4635MX system.

Refer to the “Printer options” section earlier in this chapter for information about each of the options above.

Figures 2-4 through 2-8 illustrate each of the five printer configurations available.

**Note:** Figures 2-4 through 2-8 show the 4635 LPS with the optional bar code device.

Figure 2-4. **Printer + Inverter Feeder Stacker + Feeder Stacker + optional bar code device**

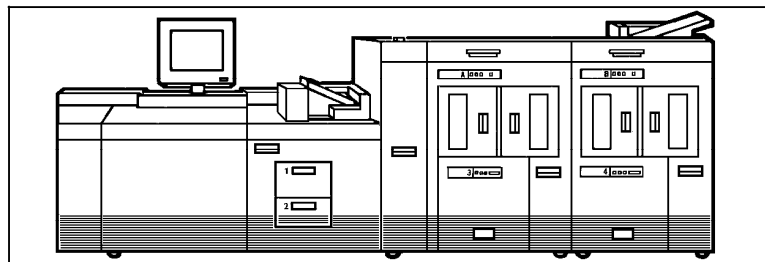

Figure 2-5. **Printer + Inverter Feeder Stacker + Feeder Stacker + Bypass Transport + optional bar code device**

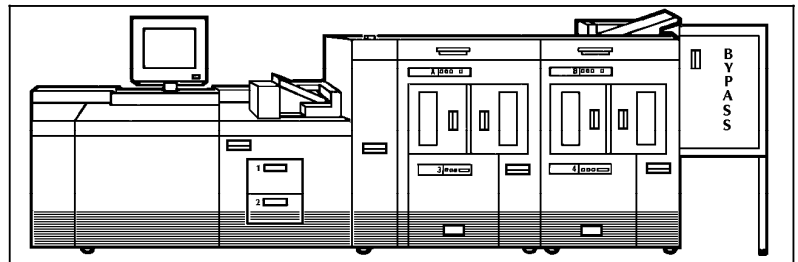

Figure 2-6. **Printer + Inverter Feeder Stacker + Feeder Stacker + Feeder Stacker + optional bar code device**

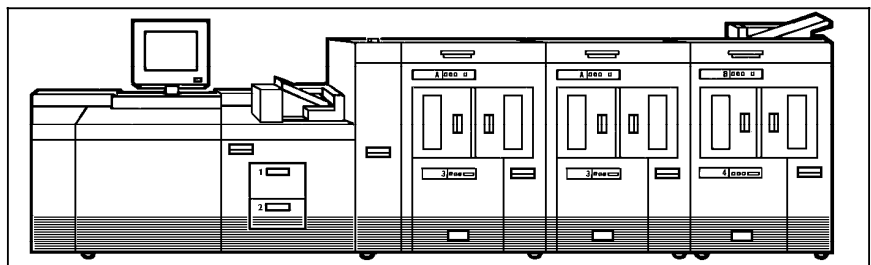

Figure 2-7. **Printer + Inverter Feeder Stacker + Feeder Stacker + Feeder Stacker + Bypass Transport + optional bar code device**

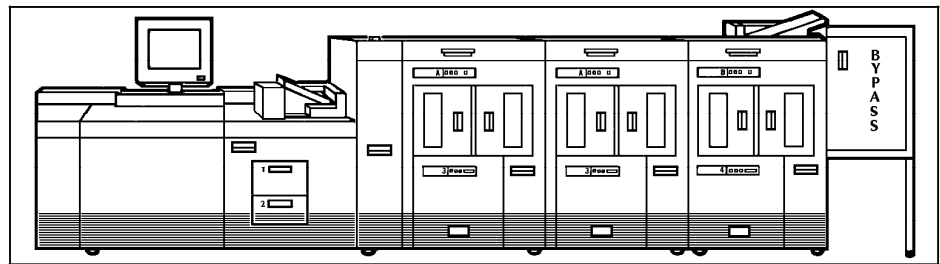
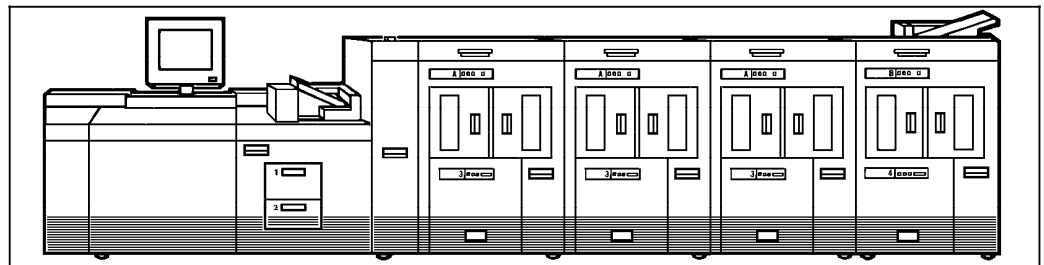

Figure 2-8. **Printer + Inverter Feeder Stacker + Feeder Stacker + Feeder Stacker + Feeder Stacker + optional bar code device**



---

## Graphics

---

### Enhanced Advanced Image Processor (EAIPX)

---

EAIPX is the controller board of the Advanced Imaging Subsystem (AIS) boards set. EAIPX enables the 4635 LPS to receive digitized graphic data.

### Graphic scanning

---

Scanner options allow you to take advantage of the LPS's high resolution printing capabilities by transmitting and receiving graphic images from a variety of sources. The scanner converts line drawings and other graphic images into electronic form for printing on the LPS, storing, or transmitting to another device.

#### **Xerox 7650 Pro Imager**

---

The Xerox 7650 Pro Imager is a tabletop image digitizer that enables numerous graphics scanning and digital imager processing functions. Ethernet and the Xerox Publishing Illustrator's Workstation (XPIW) enable your LPS to receive and print scanned graphic data (both line art and continuous tone images) from the 7650 Pro Imager.

### Raster Image Processor

---

The Raster Image Processor (RIP) is an optional printer wire board which allows your 4635 LPS to print complex groupings of data, fonts, forms, graphics, and vector graphics.

---

## Host-resident software packages

---

### Xerox Pen Plotter Interface/XDGI

---

Xerox Pen Plotter Interface (XPPI)/XDGI interfaces with your host computer applications graphics software and converts vector information to raster information.

### Host Forms Description Language

---

Host Forms Description Language (HFDL) enables forms to be created and modified on the host, merged with other data, and printed on the LPS. HFDL eliminates the need for preprinted forms and saves time in forms creation by using English-like commands.

### Xerox Printer Access Facility

---

Xerox Printer Access Facility (XPAF) enhances the capabilities and use of your LPS in an IBM MVS/XA environment. For example, it allows you to change printer destinations without restructuring the data stream. XPAF accepts numerous types of data streams, transforms and conditions them, and then sends them to the selected printer.

This chapter will assist you in preparing for the installation of your 4635 Laser Printing System (LPS). Consult your customer support representative for the requirements of any optional equipment or communications devices that may have been ordered. For example, the peripheral cabinet and bypass transport options have space requirements, and Ethernet requires that you establish an Ethernet address. Refer to the "LPS options" chapter of this guide for further information.

Keep in mind that preparing for your LPS installation is a responsibility shared by both your site and your Xerox or Rank Xerox representatives. Your representatives are available to discuss installation issues and to assist you in completing the site installation responsibilities.

Prior to installation, a site must be carefully selected and prepared, and supplies must be ordered. This chapter will help you accomplish these tasks by providing the following information:

- LPS space and delivery requirements
- Environmental and electrical requirements
- Cabling requirements
- Supply requirements.

If you have purchased additional equipment for use with your 4635 LPS, such as finishers or feeders, from a company other than Xerox, it is important to remember to work with the representatives of the company when planning the installation. Space planning, electrical and environmental requirements, and so forth, are important considerations to remember.

---

## LPS space and delivery requirements

---

Dimensions and weights of the 4635 LPS system controller and printer are listed in this chapter, along with diagrams to help you visualize the sizes and total space requirements.

**Note:** There must be a 78-inch/1981-mm vertical clearance throughout the entire area. In addition, your LPS must be installed in a fixed location with a minimum clearance space of 36 inches/914 mm around all sides of each piece of equipment for access by service personnel. 50 inches/1270 mm clearance is required in front of the 4635 printer (refer to figure 3-3).

For information on sharing space and other space planning considerations, refer to the "Space planning guidelines" section of this chapter. Space planning templates, a space planning template transparency, and a grid are also provided at the end of this chapter to assist you in planning the placement of your 4635 LPS. Contact your service representative if you have questions not specifically addressed in this guide.

The following diagrams represent top views of the components, surrounded by the required minimum clearance on all sides.

## System controller

### System controller

The dimensions of the system controller are:

- Width: 24 inches/610 mm
- Depth: 28 inches/712 mm
- Height: 38.2 inches/970 mm
- Weight: 300 pounds/136 kg (fully loaded)

Total space requirement: 96 inches/2438 mm by 100 inches/2540 mm

Figure 3-1 shows the dimensions and space requirements for the system controller.

Figure 3-1. **4635 system controller dimensions and space requirements (top view)**

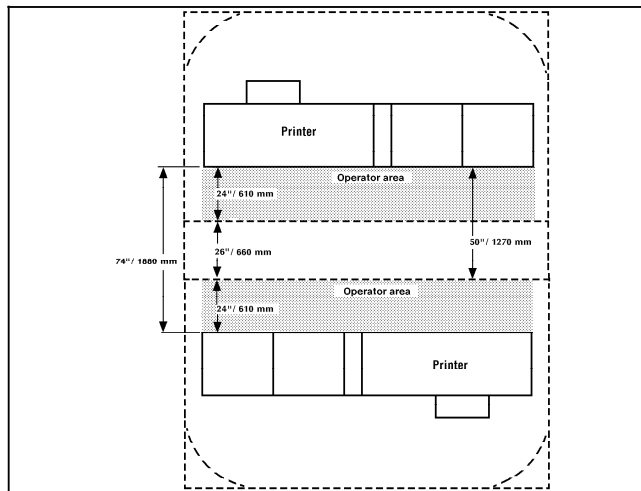

### System controller with peripheral cabinet

The optional peripheral cabinet has the same height, depth, and width requirements as the system controller cabinet. Figure 3-2 shows the minimum space requirements for the system controller with the peripheral cabinet. It is not necessary to position the cabinets directly adjacent to one another. The cabinets can be separated by up to the length of the data cable connecting them.

The weight of the peripheral cabinet fully loaded with the 9-track and 18-track tape drives is 316 pounds/144 kg.

**Note:** The 1/4-inch cartridge tape is housed within the system controller and has no unique space requirements.



Figure 3-2 shows the dimensions of the system controller with the peripheral cabinet.

Figure 3-2. **4635 system controller with peripheral cabinet dimensions and space requirements (top view)**

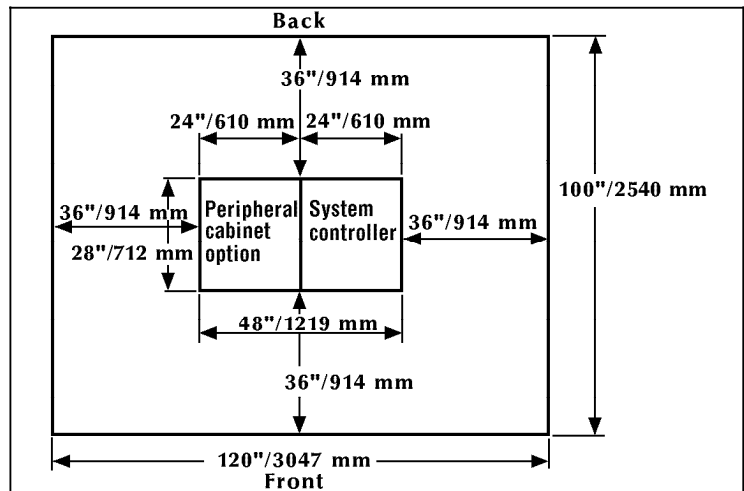

## Printer

This section lists and illustrates the dimensions of the following printer configurations:

1. Printer + Inverter Feeder Stacker + Feeder Stacker
2. Printer + Inverter Feeder Stacker + Feeder Stacker + Bypass Transport
3. Printer + Inverter Feeder Stacker + Feeder Stacker + Feeder Stacker
4. Printer + Inverter Feeder Stacker + Feeder Stacker + Feeder Stacker + Bypass Transport
5. Printer + Inverter Feeder Stacker + Feeder Stacker + Feeder Stacker + Feeder Stacker

**Printer with an inverter feeder/stacker and a feeder/stacker**

The dimensions and the space requirements of the printer with the inverter feeder/stacker and a feeder/stacker are shown in figure 3-3.

Figure 3-3. **4635 printer dimensions with inverter feeder/stacker and feeder/stacker modules (top view)**

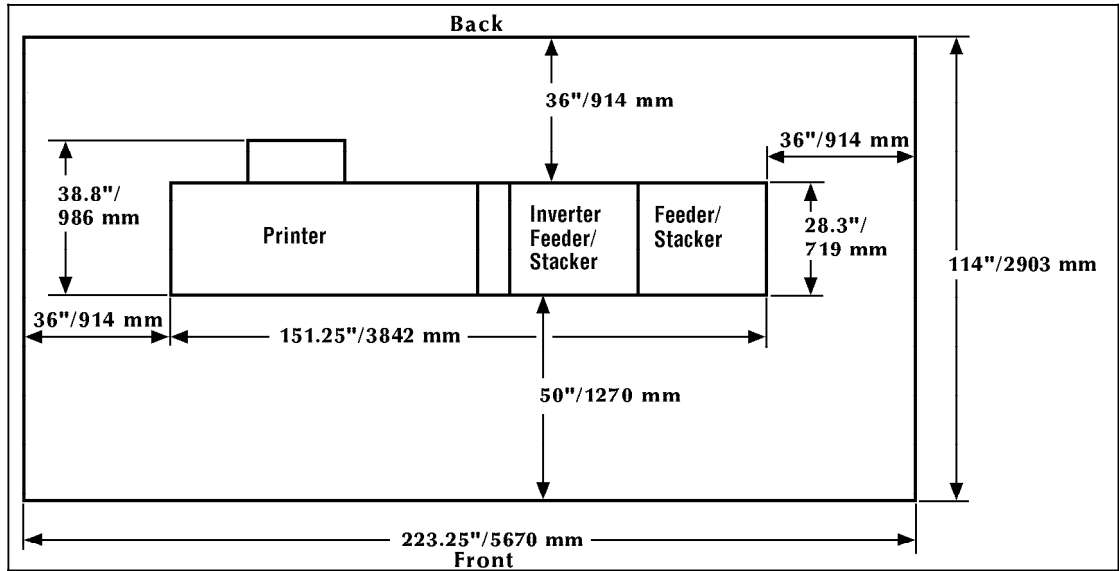

**Printer with an inverter feeder/stacker, feeder/stacker, and a bypass transport**

The dimensions and the space requirements of the printer with the inverter feeder/stacker, feeder/stacker and a bypass transport are shown in figure 3-4.

Figure 3-4. **4635 printer dimensions with inverter feeder/stacker, feeder/stacker, and bypass transport modules (top view)**

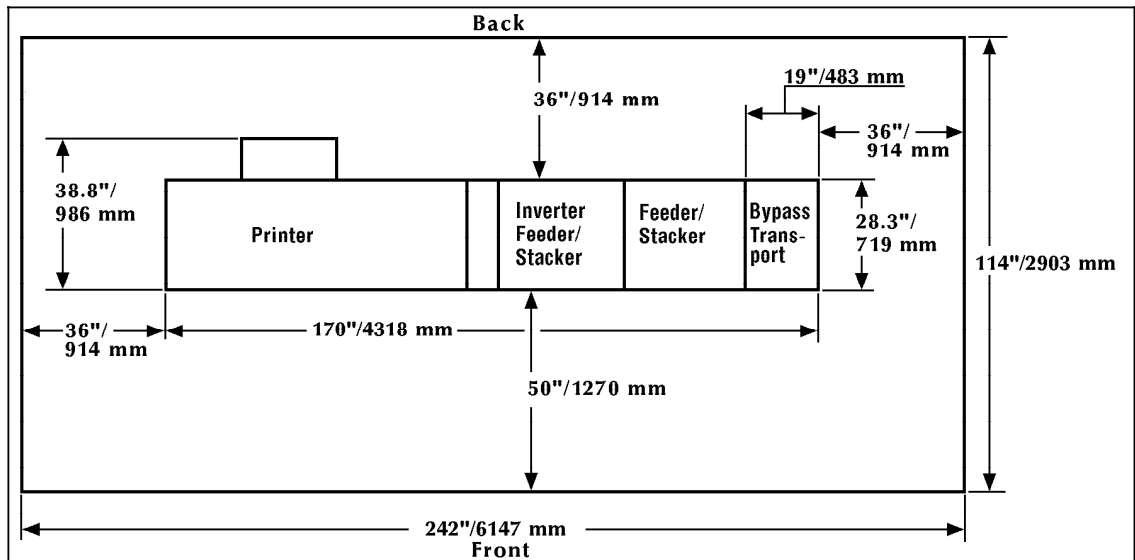

**Printer with an inverter feeder/stacker and two feeder stackers**

The dimensions and the space requirements of the printer with the inverter feeder/stacker and two feeder stackers are shown in figure 3-5.

Figure 3-5. **4635 printer dimensions with inverter feeder/stacker and two feeder/stacker modules (top view)**

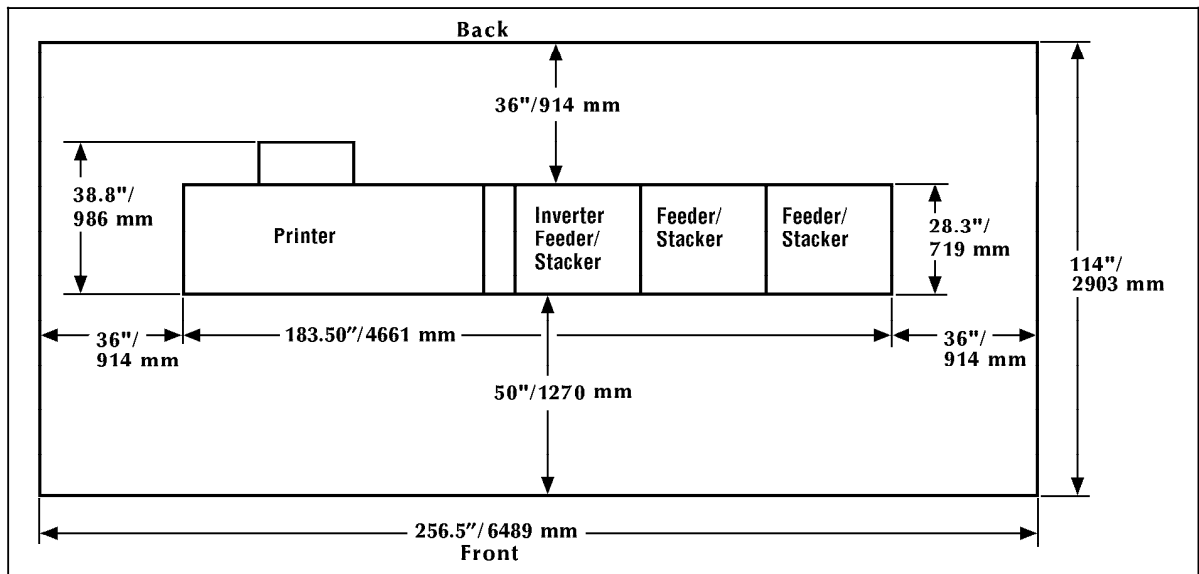

**Printer with an inverter feeder/stacker, two feeder stackers and a bypass transport**

The dimensions and the space requirements of the printer with the inverter feeder/stacker, two feeder stackers and the bypass transport are shown in figure 3-6.

Figure 3-6. **4635 printer dimensions with inverter feeder/stacker, two feeder/stackers and the bypass transport modules (top view)**

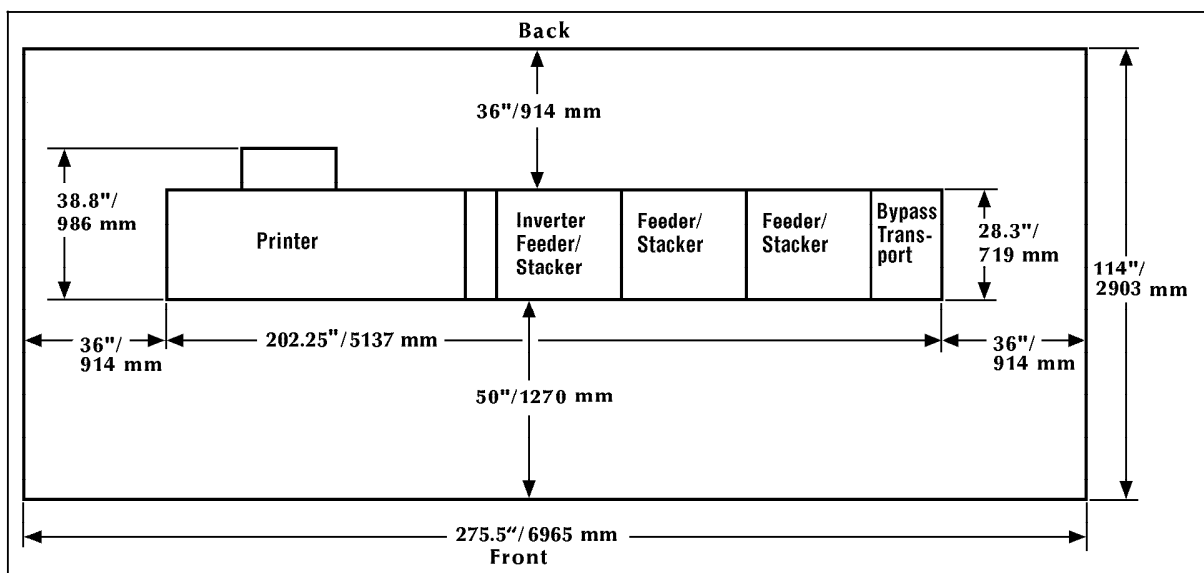

**Printer with an inverter feeder/stacker and three feeder stackers**

The dimensions and the space requirements of the printer with the inverter feeder/stacker and three feeder/stackers are shown in figure 3-7.

Figure 3-7. **4635 printer dimensions with inverter feeder/stacker and three feeder/stacker modules (top view)**

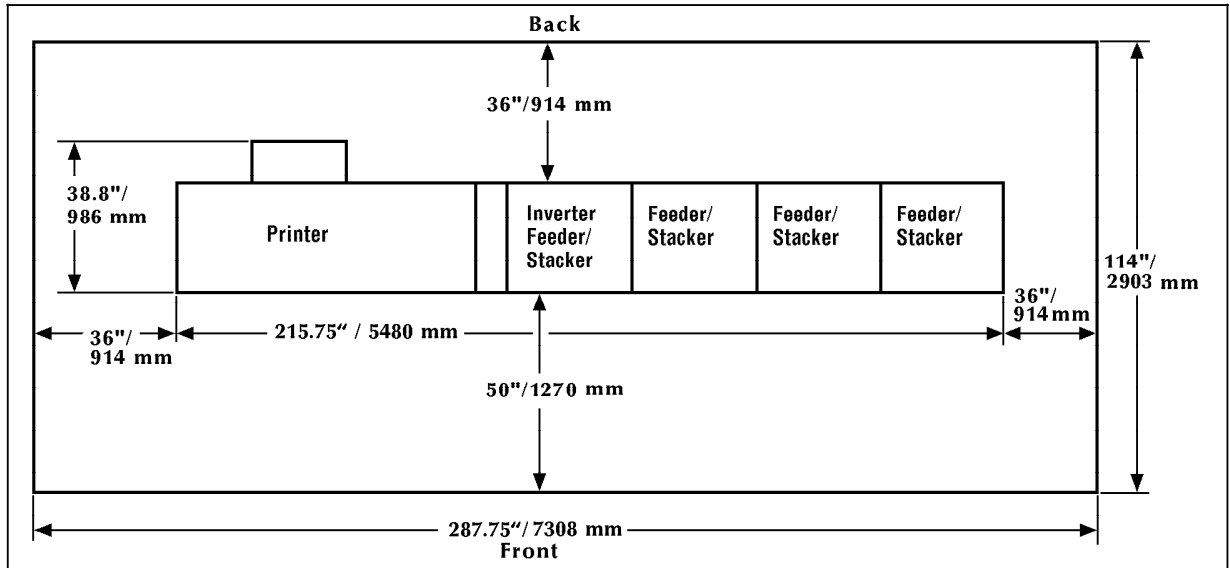

---

## Space planning guidelines

---

### Clearance space requirements

---

Your 4635 LPS must be installed in a fixed location and have:

- 36 inches/914 mm of clearance on all sides of each component, including any finishers or feeders you have attached to your 4635 LPS. 50 inches/1270 mm clearance is required at the front of the printer
- 78 inches/1981 mm of vertical clearance throughout the entire area
- 24 inches/610 mm of exclusive operator area in front of each component.

### Shared space

---

It is always best to provide the full amount of clearance space around your LPS. It is sometimes necessary, however, to have shared space between components, such as between the printer and the system controller, or between the 4635 LPS and another printing system. It is possible to share the 36-inch/914-mm clearance space around each component, but there are three rules which must always be observed:

- Space may be shared only with other Xerox equipment.
- Components may share the 36-inch/914-mm general service clearance areas, but they may not share the 24-inch/61-mm operator area in front of each component.
- There must be 78 inches/1981 mm of vertical clearance throughout the entire area.

**Note:** Finishers attached to your bypass transport and feeders attached to your 4635 LPS through the input enablement device may occupy shared space with Xerox equipment. However, they must meet the Xerox DFA Level 1 specifications and be removable to allow servicing of the 4635 LPS feeder/stackers. Consult with your Xerox or Rank Xerox representatives to ensure all the requirements are met.

Figures 3-8 and 3-9 illustrate two possible configurations of shared space. In the first illustration, two printers are back to back. Because there is no operator area to be concerned with, the entire 36 inches of general service space may be shared.

Figure 3-8. **Back-to-back shared service area space**

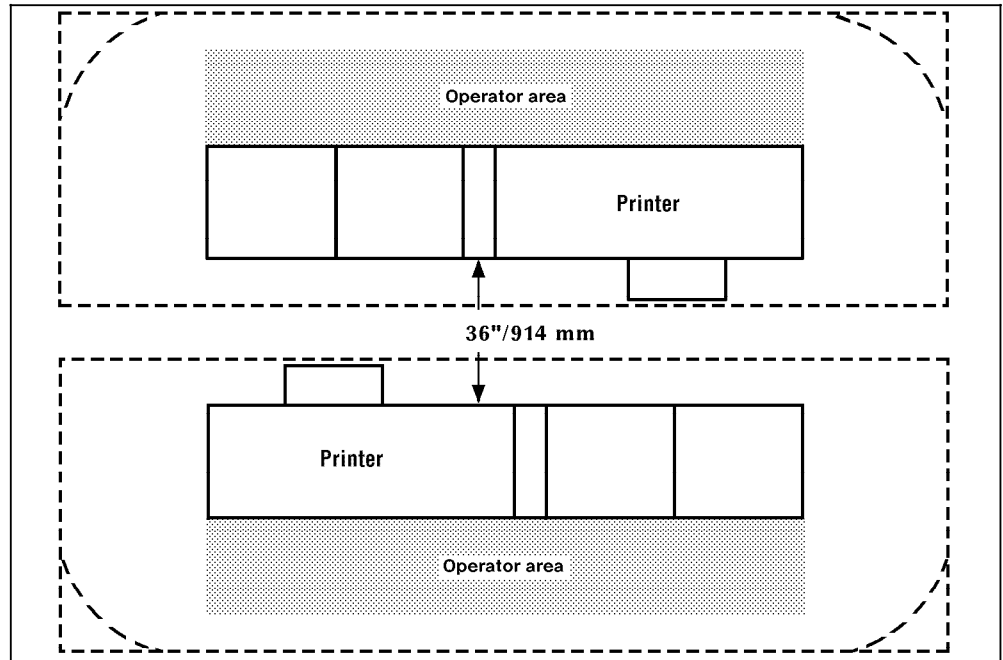
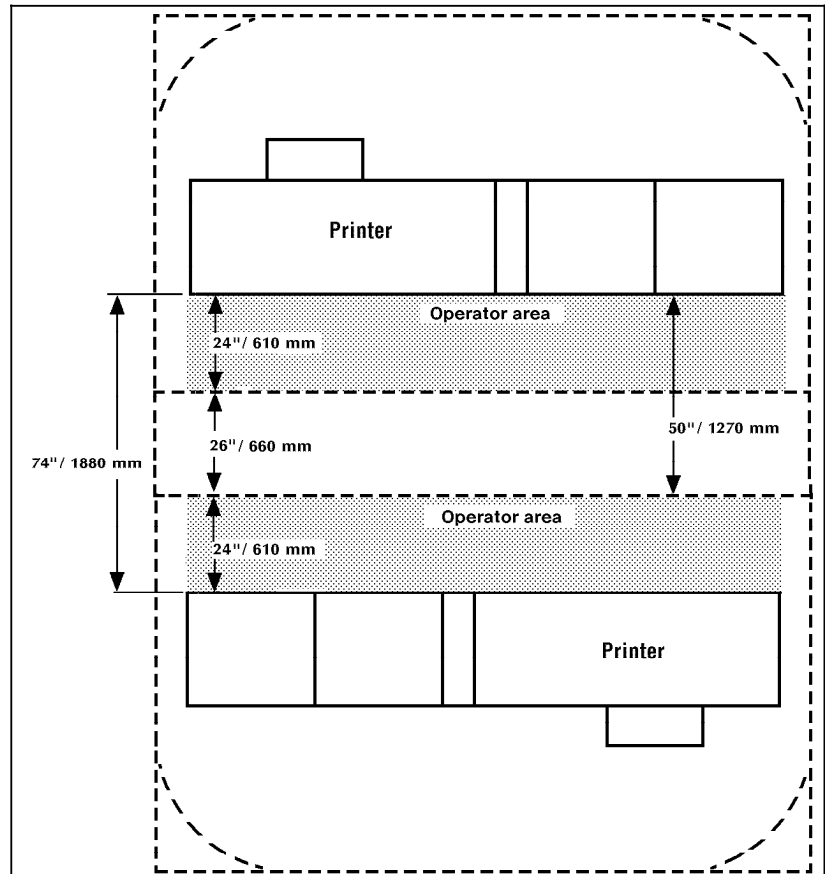

Figure 3-9 shows the minimum service space required between two 4635 printers positioned face-to-face. The printers should be separated by at least 74 inches/1880 mm. This allows enough space for the front panels of one printer to be opened, without obstructing the 24 inch/610 mm operator area of the other printer.

Figure 3-9. Face-to-face shared service area space



When determining your space requirements and planning for shared space between your LPS, it is important to consider all the components you plan to have installed. If you have an optional bypass transport or input enablement device on your 4635 LPS, you need to consider the size and configuration of the finishers and feeders you purchase. A finisher can add considerable length to your LPS and possibly consume space in front of your LPS. Your feeder may require a large amount of space behind your LPS.

The 36-inch/914-mm clearance space around each component must be observed for your feeders and finishers, therefore, must be considered when planning configuration of your systems. To ensure all the space requirements are met, it is important to work with your Xerox or Rank Xerox representatives, as well as the representatives of the company from which you have purchased your finishers and feeders.

## Cable lengths

Cable lengths are important considerations in planning your LPS layout, as components cannot be separated by more than the recommended cable distance. These distances affect these placements:

- The printer and the system controller
- The PC UI
- The optional peripheral cabinet.

**Note:** There are also distance requirements for some LPS options. Please consult with your customer support representative for these requirements.

### Data cables

4635 LPS components can be separated up to the length of the data interface cables that connect them.

- The printer and the system controller are connected by a 50-foot/15.24-m data cable.
- The system controller and the PC UI are connected by a 25-foot/7.62-m data cable.
- The system controller and the optional peripheral cabinet are connected by a 10-foot/3-m data cable.

Refer to figure 3-10 for the power and data cable locations and lengths.

Figure 3-10. Power cable and data cable length

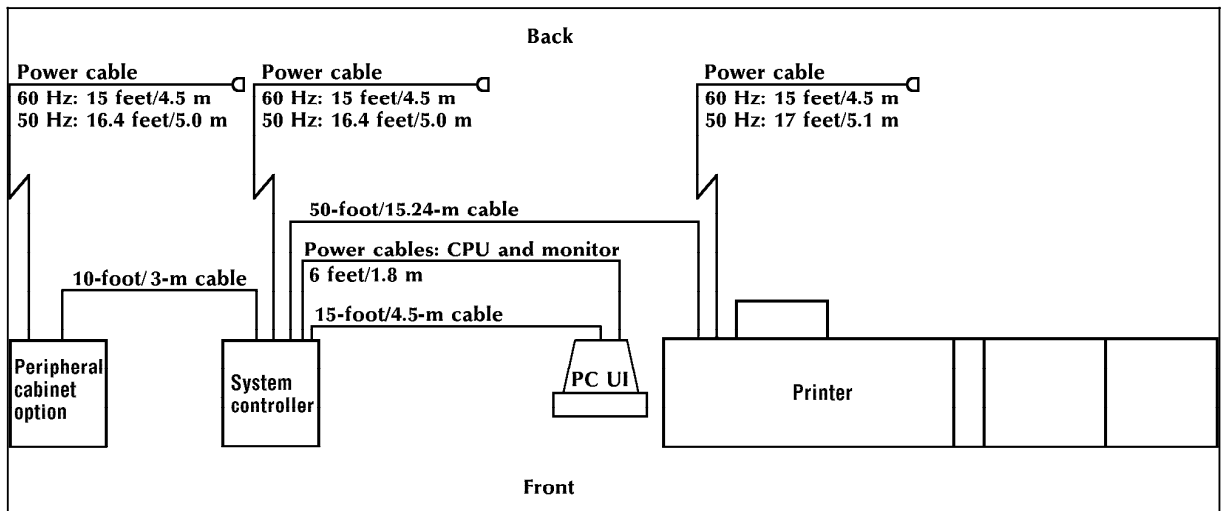



**Power cables** 4635 LPS power cable lengths are as follows:

System controller:	15 feet/4.5 m
Printer:	15 feet/6 feet/1.8 m/4.5 m (60 Hz) 17 feet/5.1 m (50 Hz, no plug)
PC UI:	6 feet/1.8 m
Peripheral cabinet option:	15 feet/4.5 m

**Note:** Cable length loss must be factored in if equipment is installed in a raised-floor environment. You should also consider that part of a cable's length is routed inside the equipment to connect with interior power or data receptacles.

## Cable locations

To run the cables beneath the flooring effectively, you need to know where the cables enter and exit the printer and the system controller. Figure 3-11 shows those locations (marked with an X).

Figure 3-11. **Cable enter/exit locations (top view)**

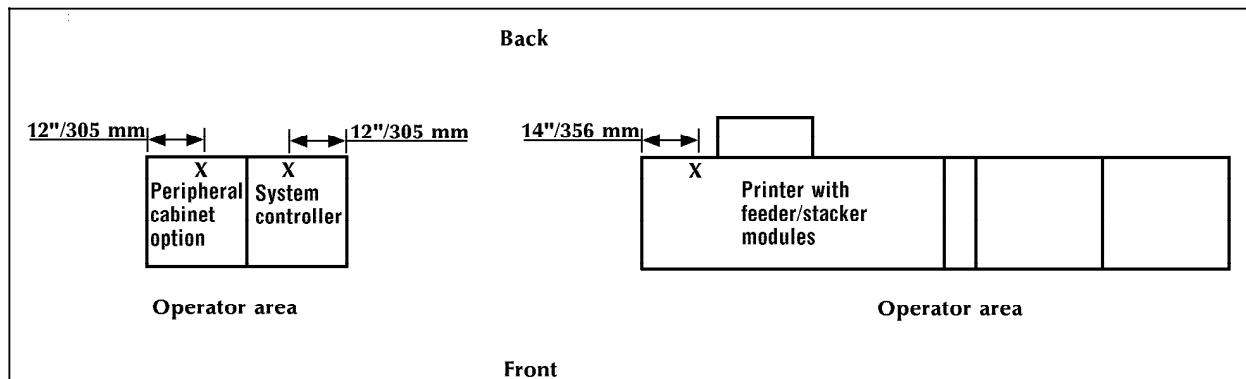

## Efficiency of use

There are many possible layouts for your LPS. Placement depends on the type and amount of equipment used and the size and shape of the room used to house the equipment. Some possible configurations for LPS components include:

- Side by side
- L-shaped
- Face to face.

Equipment placement should limit operator movements as much as possible. Here are a few suggestions that may be helpful:

- Place the system controller as close to the output end of the printer as possible. This will enable operators to simply reach over to collect printed materials and check output.
- Consider the location of supplies in relation to the placement

of the equipment. For example, having paper as close to the printer as possible will save time.

- Having the system controller as close as possible to any offline interface devices saves time when monitoring tapes, jobs, and so forth.

## Delivery access requirements

---

It is easy to overlook how the equipment is going to get from the truck to the operation site. Does it need to go up stairs? Do you have an elevator if it is to be located above the first floor? Is the elevator large enough? How wide are the hallways? The doorways? Do you have a loading dock or a specific door to which the equipment should be delivered?

All these issues need to be reviewed prior to or at the time of the site inspection that is done by your service representative.

The equipment dimensions are specified earlier in this chapter, so it is easy to know whether or not your hallways and doorways are wide enough to permit travel through them.

### Turning radius

The width of the passageway when the equipment must negotiate a corner, whether into a room (or elevator) or into another passageway, must also be considered.

The 4635 is delivered with the printer, inverter feeder/stacker, and the feeder/stacker as three separate modules. If necessary, the printer can be separated into two pieces for easier moving. The larger of the two parts contains the xerographic system; the smaller of the parts (referred to here as the PHM) contains paper trays 1 and 2. Table 3-1 describes the turning requirements for the printer when attached to the PHM (not separated). Table 3-2 describes requirements for the printer without the PHM (separated). Do not confuse these two parts of the printer with the inverter and feeder/stacker modules, which have their own turning requirements.

Table 3-3 describes the turning requirements for the printer if it is upended for easier moving or stair-climbing. This table reflects requirements for the printer separated from the PHM.

Tables 3-4 and 3-5 describe the turning requirements for the inverter/feeder/stacker and the feeder/stacker modules.

The relatively small dimensions of the 4635 system controller and the optional peripheral cabinet are not likely to be of concern during delivery. Refer to figures 3-1 and 3-2 for their dimensions.

The diagrams and the tables that follow show the minimum space needed to maneuver through a turn. To use the tables, measure the passage or doorway width into which you wish to go at its minimum width. This is Passage A. Find that number (or the next higher number) on the appropriate table and read across to the corresponding minimum value for Passage B (the passage or doorway you are turning from).

Table 3-1. Turning radius for printer (not separated)

Passage or doorway A width	Minimum passage B width
29 inches/737 mm	83 inches/2108 mm
30 inches/762 mm	76 inches/1930 mm
31 inches/787 mm	73 inches/1854 mm
32 inches/813 mm	70.5 inches/1791 mm
34 inches/864 mm	66.5 inches/1690 mm
36 inches/914 mm	63.5 inches/1613 mm
38 inches/965 mm	61.5 inches/1562 mm
40 inches/1016 mm	58 inches/1473 mm
42 inches/1067 mm	55 inches/1397 mm

Table 3-2. Turning radius for printer (separated from PHM)

Passage or doorway A width	Minimum passage B width
29 inches/737 mm	74.5 inches/1892 mm
30 inches/762 mm	64.5 inches/1638 mm
31 inches/787 mm	62 inches/1575 mm
32 inches/813 mm	59.5 inches/1511 mm
34 inches/864 mm	56 inches/1422 mm
36 inches/914 mm	53 inches/1346 mm
38 inches/965 mm	50 inches/1270 mm
40 inches/1016 mm	48 inches/1219 mm
42 inches/1067 mm	45.5 inches/1156 mm

Table 3-3. Turning radius for printer (separated and upended on dolly)

Passage or doorway A width	Minimum passage B width
30 inches/762 mm	49 inches/1245 mm
31 inches/787 mm	43 inches/1092 mm
32 inches/813 mm	41 inches/1041 mm
34 inches/864 mm	37.5 inches/953 mm
36 inches/914 mm	35 inches/889 mm
38 inches/965 mm	33.5 inches/851 mm
40 inches/1016 mm	32 inches/813 mm
42 inches/1067 mm	31 inches/787 mm

Table 3-4. Turning radius for inverter/feeder/stacker module

Passage or doorway A width	Minimum passage B width
29 inches/737 mm	43 inches/1092 mm
30 inches/762 mm	41 inches/1041 mm
31 inches/787 mm	40 inches/1016 mm
32 inches/813 mm	38 inches/965 mm
33 inches/838 mm	37 inches/940 mm
34 inches/864 mm	36 inches/914 mm
35 inches/889 mm	35 inches/889 mm
36 inches/914 mm	34 inches/864 mm
37 inches/940 mm	33 inches/838 mm
38 inches/965 mm	32 inches/813 mm
39 inches/991 mm	31 inches/787 mm
40 inches/1016 mm	31 inches/787 mm
41 inches/1041 mm	30 inches/762 mm
42 inches/1067 mm	29 inches/737 mm
43 inches/1092 mm	29 inches/737 mm

**Note:** These turning figures are based on the following inverter/feeder/stacker dimensions:

28 inches/711 mm by 42 inches/1067 mm

Table 3-5. Turning radius for feeder/stacker module

Passage or doorway A width	Minimum passage B width
29 inches/737 mm	33 inches/838 mm
30 inches/762 mm	32 inches/813 mm
31 inches/787 mm	31 inches 787 mm
32 inches/813 mm	30 inches/762 mm
33 inches/838 mm	29 inches/737 mm

**Note:** These turning figures are based on the following feeder/stacker dimensions:

28 inches/711 mm by 32.25 inches/819 mm

## Environmental/electrical requirements

Your 4635 LPS has important environmental and electrical requirements that must be accommodated. These requirements are summarized in the table below. For further details on electrical requirements, refer to the following voltage charts and wiring diagrams.

Table 3-6. **4635 environmental and electrical requirements**

Environmental requirements	
Operating temperature	Recommended: 74° F ± 4° F/24° C ± 4° C Minimum: 54° F/14° C Maximum: 85° F/29° C
Humidity	Recommended: 45% ± 10% Minimum: 15% Maximum: 85%
Altitude	Normal: Up to 6,000 feet/1830 m above sea level Maximum: 9,000 feet/2743 m above sea level
Heat dissipation	
System controller	3,754 Btu per hour
Peripheral cabinet (fully configured)	3,195 Btu per hour
Printer	Operating: 28,140 Btu per hour Standby: 4,454 Btu per hour (fuser on) Energy Saver: 2,7000 Btu per hour
System controller	U.S. and Canada, 60 Hz: 208/240 VAC (1 phase) or 208/220 VAC (Line 1 to Line 2); 15 amp service NEMA 6-15R or ANSI C73, 20R KVA 1.1 (operating) International, 50 Hz: 200/230 VAC (1 phase) 15 amp service; Power connector per local codes
Printer	U.S. and Canada, 60 Hz: 120/240 VAC or 120/208 VAC; 50 amp service; NEMA 14-50R KVA 7.3 (operating) International, 50 Hz (WYE): 380, 400, 415 VAC (3 phase, 5 wire); 20 amp service (WYE) International, 50 Hz (DELTA): 220, 230, 240 VAC (3 phase, 4 wire); 30 amp service (DELTA)

Table 3-6. **4635 environmental and electrical requirements**  
(continued)

<b>Electrical requirements</b>	
Audible noise	Standby: Continuous: 52 dB (A) Impulse: N/A Operating: Continuous: 67 dB (A) Impulse: 72 dB (A)
Optional peripheral cabinet	U.S. and Canada, 60 Hz: 208/240 VAC (1 phase) or 208/220 VAC (Line 1 to Line 2); 15 amp service; NEMA 6-15R or ANSI C73, 20R KVA .9 in both standby and operating International, 50 Hz: 200/230 VAC (1 phase); 15 amp service; Power connector per local codes
Optional bypass transport	The power requirements for the bypass transport module are all satisfied by the 4635 LPS printer module.
Agency certification	UL, CSA, IEC, VDE

### 4635 LPS power receptacle requirements

All power outlets must be dedicated only to this equipment. Ensure that each power cord has a separate circuit.

You must use a power cord assembly (ELCI, RCD Inline, 220 VAC) when using a source other than the system controller to provide power to your PC UI. Contact your sales and service representative to ensure the proper assembly is ordered and installed.

Ensure that the power cord configurations match your receptacle requirements (tables 3-7 and 3-8).

50 Hz systems: Consult with your local service representative to determine the type of plug and receptacle to use with your 50 Hz printer and system controller.

Table 3-7. **Printer power receptacle requirements**

<b>Electrical environment</b>	<b>Voltage/current</b>	<b>Receptacle</b>
U.S. and Canada 60 Hz	120/240/50A or 120/208/50A	NEMA 14-50R
International 50 Hz WYE	380,400,415/20A (WYE), 3 Phase, 5 wire	Per local code
International 50 Hz DELTA	220,230, 240/30A (DELTA), 3 Phase, 4 wire	Per local code

Table 3-8. **System controller and peripheral cabinet power receptacle requirements**

Electrical environment	Voltage	Current	Receptacle
U.S. and Canada 60 Hz	208/240, 1 Phase or 220/230 (L1-L2)	15A	NEMA 6-15R or ANSI C73, 20R
International 50 Hz	220/230 1 Phase	15A	Per local code

## 50 Hz WYE printer outlet voltages

**Note:** All power outlets must be dedicated only to this equipment. Ensure that each power cord has a separate circuit.

50 Hz WYE configurations only: Measure the WYE connection voltages at the power source. Table 3-9 shows 415 voltages. Table 3-10 shows 380 and 400 voltages.

Table 3-9. **Printer (50 Hz only) WYE connection for 415 V Service outlet**

Service outlet configuration	Measurement	Nominal	Range
5 Wire 415 V	Line 1 to Line 2	415 V RMS	374-457 V RMS
5 Wire 415 V	Line 2 to Line 3	415 V RMS	374-457 V RMS
5 Wire 415 V	Line 1 to Line 3	415 V RMS	374-457 V RMS
5 Wire 415 V	Line 1 to Neutral	240 V RMS	216-264 V RMS
5 Wire 415 V	Line 2 to Neutral	240 V RMS	216-264 V RMS
5 Wire 415 V	Line 3 to Neutral	240 V RMS	216-264 V RMS

Table 3-10. **Printer (50 Hz only) WYE connection for 380 V and 400 V**

Service outlet configuration	Measurement	Nominal	Range
5 Wire 380 V	Line 1 to Line 2	380 V RMS	342-419 V RMS
5 Wire 380 V	Line 2 to Line 3	380 V RMS	342-419 V RMS
5 Wire 380 V	Line 1 to Line 3	380 V RMS	342-419 V RMS
5 Wire 380 V	Line 1 to Neutral	220 V RMS	198-242 V RMS
5 Wire 380 V	Line 2 to Neutral	220 V RMS	198-242 V RMS
5 Wire 380 V	Line 3 to Neutral	220 V RMS	198-242 V RMS
5 Wire 400 V	Line 1 to Line 2	400 V RMS	358-438 V RMS
5 Wire 400 V	Line 2 to Line 3	400 V RMS	358-438 V RMS
5 Wire 400 V	Line 1 to Line 3	400 V RMS	358-438 V RMS
5 Wire 400 V	Line 1 to Neutral	230 V RMS	207-253 V RMS
5 Wire 400 V	Line 2 to Neutral	230 V RMS	207-253 V RMS
5 Wire 400 V	Line 3 to Neutral	230 V RMS	207-253 V RMS

## 50 Hz DELTA printer outlet voltages

**Note:** All power outlets must be dedicated only to this equipment. Ensure that each power cord has a separate circuit.

Consult with your service representative to determine the type of plug and receptacle to be used for your 50 Hz printer.

**50 Hz DELTA configurations only:** Measure the DELTA connection voltages at the power source. The required voltages are shown in table 3-11.

Table 3-11. **Printer (50 Hz only) DELTA**

Service outlet configuration	Measurement	Nominal	Range
4 Wire 220V V	Line 1 to Line 2	220 V RMS	198-242 V RMS
4 Wire 220V V	Line 2 to Line 3	220 V RMS	198-242 V RMS
4 Wire 220V V	Line 1 to Line 3	220 V RMS	198-242 V RMS
4 Wire 230 V	Line 1 to Line 2	230 V RMS	207-253 V RMS
4 Wire 230 V	Line 2 to Line 3	230 V RMS	207-253 V RMS
4 Wire 230 V	Line 1 to Line 3	230 V RMS	207-253 V RMS
4 Wire 240 V	Line 1 to Line 2	240 V RMS	216-264 V RMS
4 Wire 240 V	Line 2 to Line 3	240 V RMS	216-264 V RMS
4 Wire 240 V	Line 1 to Line 3	240 V RMS	216-264 V RMS



## 50 Hz system controller and peripheral cabinet power cord configurations

Figure 3-12 shows the 50 Hz system controller power cord configuration.

Figure 3-12. **System controller and peripheral cabinet power cord 50 Hz installation 200/230 VAC, single phase, 15A**

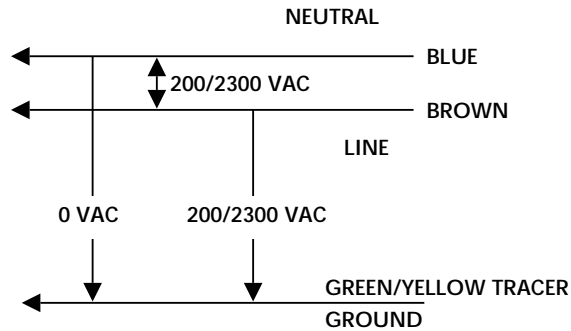

Note that 50 Hz plug and receptacle specifications vary according to local codes.

## 60 Hz printer outlet voltages

**Note:** All power outlets must have a dedicated circuit for each system equipment piece. Ensure that each power cord has a separate circuit.

Refer to table 3-12 for the 60Hz voltage requirements at the power outlet.

Table 3-12. **Printer (50 Hz) voltage requirements at power outlet**

Service outlet configuration	Measurement	Nominal	Range
4 Wire	Line 1 to Neutral	120 V RMS	107-127 V RMS
4 Wire	Line 2 to Neutral	120 V RMS	107-127 V RMS
4 Wire	Neutral to Ground	0	0-10 V RMS
4 Wire	Line 1 to Line 2	208 V RMS	182-220 V RMS
4 Wire	Line 1 to Line 2	240 V RMS	210-254 V RMS

## 60 Hz system power cord configurations

Figure 3-13 shows the configuration of the 60 Hz printer power cord.

Figure 3-13. **Printer power cord 60 Hz installation for 50 amp NEMA 14-50R**

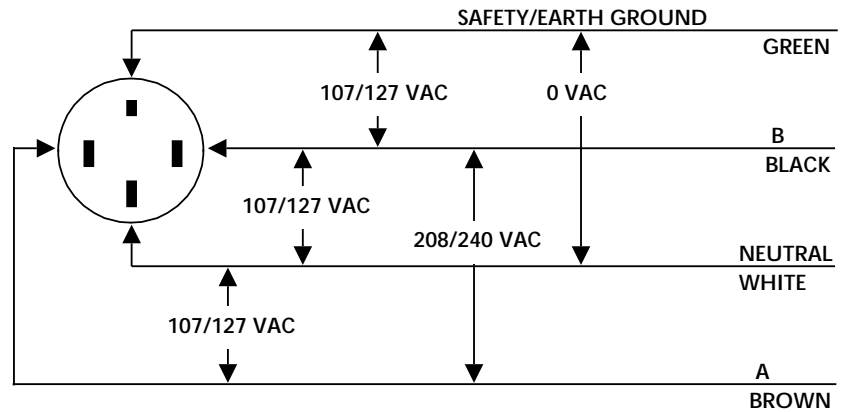

Voltage to ground is shown for troubleshooting.

Figure 3-14 shows the configuration of the 60 Hz system controller and peripheral cabinet power cord configuration.

Figure 3-14. **System controller and peripheral cabinet power cord 60 Hz installation for 15 amp NEMA 6-15R**

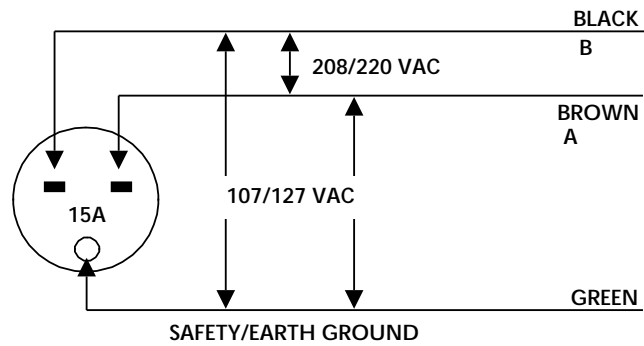

Voltage to ground is shown for troubleshooting.

---

## Finishing and feeding equipment

---

It is important to note that while the Bypass Transport and Input Enablement options provide you with an interface between your 4635 LPS and your finishing and feeding accessories, they require their own AC and DC power sources. The power must be independent of your 4635 LPS.

Consult your Xerox or Rank Xerox sales representative, as well as the sales representative of the company from which you purchased your finishing and feeding equipment, for specific electrical and space requirements.

---

## Interface requirements

---

### Channel-attached

---

For an *online* configuration with an IBM host system, the following cables must be available:

- Bus and tag cables (bus in, bus out, tag in, tag out)
- Emergency power off (EPO) cable (optional)
- Terminators (if necessary, due to location on channel).

For your convenience, it is possible to order the Bus and Tag cables for the printer through Xerox Corporation on a purchase-only basis. Contact your Xerox or Rank Xerox sales representative for current pricing and order information.

---

### Third party connections

---

Xerox supports a number of third party connections. For more information, contact your Xerox or Rank Xerox sales representative or call the Xerox Connection between 7 a.m. and 4 p.m. Pacific time at:

**1-800-451-9312** (continental U.S.)

---

## Training

---

This section describes the Operator and Systems training available for the 4635 LPS.

---

### Operator training

---

Operator training is conducted at your location shortly after your LPS has been installed. Training takes approximately four to seven hours, depending on the system configuration, and includes hands-on practice running basic jobs, maintenance, and problem solving. Determine the number of operators you want to attend initial training, and schedule training dates and times through your Xerox sales representative.

Advanced Customer Training (ACT) is available at the Xerox training center in Leesburg, Virginia. Discuss candidates for this training with your Xerox sales representative, if desired. Keep in mind that operators should not be considered for ACT until they have spent several months working with the LPS and have shown good mechanical aptitude. Call Xerox Customer Education at 1-800-445-5554 to schedule ACT.

---

### Systems training

---

Several training workshops and a self-study course are included in the LPS technical training curriculum. Workshops are designed to provide a system overview, as well as forms creation, job control, and increased productivity expertise. The workshops include the following courses:

- **LPS Introduction Workshop (8R7036).** This one-day workshop includes a technical overview of Xerox LPS features, system disk structure, operating system software, the system generation procedure, disk utilities, problem solving, and an introduction to command files. Hands-on experience includes configuring and generating a new software system and performing maintenance procedures using the LPS utility commands.
- **LPS Forms Description Language (FDL) Workshop (8R7030).** This one-day workshop provides instruction on FDL commands, inserting logos and graphics, using the forms design ruler and quick reference card, coding and printing electronic forms, modifying a form to print variable data, and converting to a two-up format.
- **LPS FDL Self Study Kit (600P87918) and LPS FDL Self Study (600P87918A).** This self-study option for FDL training provides all of the information presented in the FDL Workshop as well as exercises to be completed on your LPS.
- **LPS Print Description Language (PDL) Workshop (8R7033).** This three-day workshop provides lecture and hands-on practice for using PDL commands to identify the source and format of input to the LPS, using special processing options, defining how printed documents should be formatted, merging forms with variable data, specifying when and where various fonts, typestyles, and sizes should be used within a

job, employing Dynamic Job Descriptor Entries (DJDEs), and creating and compiling Job Description Libraries (JDLs).

- **LPS Print Description Language (PDL) II Workshop (8R7035).** This two-day workshop combines lecture and lab work to help students apply advanced PDL techniques in maximizing system productivity and developing new applications for the LPS.
- **LPS Command File Workshop (8R7089).** This is a modularized two-day workshop that provides self-paced training on such activities as establishing menus, providing system security, effective file maintenance, merging variable data on electronic forms, simplifying accounting file information, manipulating files, creating new font files, effective disk management, and creating customized applications.

For detailed information about any of these courses, to enroll in workshops, or to order the self-study, call Xerox Customer Education at:

**1-800-445-5554**

---

## Ordering supplies for installation

---

Consumable supplies (those that are depleted during operation of the LPS), such as paper, dry ink, developer, and fuser agent, need to be ordered for your LPS. It is important that you have an adequate supply on hand for installation and that you maintain an adequate supply after installation.

A set of standard fonts is provided with your system (refer to the "LPS overview" chapter). If nonstandard fonts are needed, they also must be ordered from the Xerox Font Center, described in the "Postinstallation" chapter.

This section describes the fonts and supplies needed for installation. Your Xerox or Rank Xerox sales representative will help you place your initial order for fonts (if any) and supplies. The "Postinstallation" chapter provides you with the information you need to order additional supplies as you require them, a consumable supplies table, and a supplies checklist.

## Fonts

---

Data can be printed on the 4635 in many sizes and typetypes called fonts. A font is a character set which has unique characteristics, such as typetype, size, weight, orientation (portrait, landscape, inverse portrait, and inverse landscape), character spacing (fixed and proportional), line spacing, and postures (Roman, italic, and so forth).

There are three classifications of fonts:

- Standard fonts
- Licensed fonts
- Custom fonts.

**Standard fonts** Provided with your LPS operating system software is a library of

	over 250 standard 300 spi fonts, referred to as the A03 font family.
<b>Licensed fonts</b>	In addition to the library of standard fonts delivered with your LPS, over 100 licensed fonts may be ordered from the Xerox Font Center.
<b>Custom fonts</b>	Custom fonts and graphic images such as company logos and signatures can be digitized by the Xerox Font Center for use on your LPS.
<b>Receiving fonts</b>	<p>The fonts provided by the Xerox Font Center are contained on 9-track tape, 18-track cartridges, or 1/4-inch cartridges. One tape may contain several fonts, each of which is a separate file. Fonts may also be sent to the LPS from an online host computer through an IBM-compatible channel.</p> <p>As with the other initial supplies, your Xerox or Rank Xerox sales representative will assist you with determining your LPS fonts needs for installation. After installation, the Xerox Font Center can help you order additional licensed and custom fonts. (Refer to the "Xerox Font Center" section of the "Postinstallation" chapter )</p>

## Paper

---

You need to select your paper carefully; without the proper paper, you increase the probability of paper jams and misfeeds.

Your LPS can print on standard white, colored, predrilled, and preprinted (that is, letterhead and forms) paper, labels, and transparencies. They must meet the specifications set forth by Xerox for operability in the LPS. Additional information about paper for your LPS can be found in your LPS operator guide.

Use a good quality xerographic grade paper. For best results, use 20-pound/75 gsm bond xerographic grade paper. Xerox papers are specifically designed for optimal performance in your laser printing system. (Refer to the consumable supplies table at the end of chapter 5.)

Use paper within these parameters:

Lightest: 16-pound/60-gsm (grams per square meter)  
Heaviest: 110-pound/200-gsm

The 4635 accepts paper sizes as small as 7 by 10 inches/187 mm by 254 mm, with the optional 7X10 enablement kit. Larger paper sizes, such as 11 by 17 inches/297 by 432 mm, A3 (297 by 420 mm/11.69 by 16.54 inches) and B4 (257 by 364 mm/10.12 by 14.33 inches), can also be fed.

Paper has a tendency to curl under the heat that is present inside xerographic equipment. Paper with low moisture content curls less. Paper with excessive moisture content has a tendency to jam because of the greater curl.

**Note:** The maximum recommended moisture content is 5.7 percent.

Paper is fed into the LPS with the long side as the leading edge. (A3 and 11- by 17-inch paper sizes are fed short edge first.) The

grain should be parallel with the long side (long-grain) for the most reliable feeding and stacking. Purchase long-grain paper.

Keep these points in mind when preparing your paper storage area:

- Store paper in its own wrapper; do not leave it unwrapped or where it can be damaged by dampness or heat.
- Store paper on a flat surface and not on its side or edge.
- Always store in a cool, dry area.
- Store on pallets or shelves, not on the floor.
- Before use, paper should spend at least one day in the same area as the printer to allow environmental stabilization.

---

## Dry ink (toner)

---

Dry ink (also referred to as "toner") is the black powder which forms the image on the printed page. There are three cartridges of dry ink in each container. Keep an adequate supply on hand at all times. The operator can change throw-away cartridges easily with no mess. Use only dry ink that is specified for use in your LPS. (Refer to the consumable supplies table at the end of the "Postinstallation" chapter.)

**Note:** For a 4635MX system use only dry ink specifically designed for that system.

---

## Fuser agent

---

Fuser agent is a consumable item required by the LPS. Keep an adequate supply on hand for installation by the Xerox or Rank Xerox service representative.

---

## Developer

---

Developer is a required item that needs to be ordered and kept on hand. It is changed by a Xerox or Rank Xerox service representative. Use only developer specified for use in your LPS. (Refer to the consumable supplies table at the end of chapter 5.)

---

## Tapes

---

Each of the tape drives available on the 4635 LPS requires a different tape format.

The 1/4-inch QIC tape drive uses quarter-inch stream cartridge tapes. The tape data capacity should be 320 MB with 225 KB/second data transfer rate.

The optional 18-track tape drive uses 0.5-inch IBM 3480-compatible cartridge tapes with a data capacity of 200 MB. Cartridges are not available from Xerox.

The optional 9-track tape drive supports reel-to-reel 9-track 1600 bpi (PE) and 6250 bpi (GCR) encoded magnetic tapes.

---

## Space planning templates

---

The dimensions and space requirements for 4635 components are provided earlier in this chapter. The space planning templates are designed to simplify the space planning process by helping you create a floor plan for 4635 base components, particularly if you have shared clearance space.

The easiest way to use the space planning templates is to cut the transparency located at the end of this chapter and move the templates around on the grid (also located at the end of this chapter) to find the optimum placement for your LPS components. Be sure to consider other pieces of equipment, such as storage cabinets and tables, when planning space for your LPS.

The templates are to scale with the grid; each square is equal to 12 by 12 inches/305 by 305 mm. The curved dotted lines in the corners of the space perimeters indicate the corners that may be rounded off while still maintaining the required clearance space.

The templates provided are for the system controller, printer with feeder/stacker modules, and the peripheral cabinet option. Be sure to allow space for optional equipment as appropriate. Your customer support representative can help you plan space for additional components.

There are a number of factors to keep in mind when planning your site. These include:

- Clearance space requirements
- Cable length
- Efficiency of use.

Refer to these sections when considering the various factors in planning the appropriate location for your 4635 LPS.

When determining your space requirements, remember to consider all the components you plan to have installed. If you have a bypass transport or input enablement device option on your 4635 LPS, you need to work with the sales representatives of the company from which you purchase your finishers and feeders, as well as your Xerox or Rank Xerox representatives, to ensure space requirements are met.

Refer to figure 3-15 when determining your space requirements.



Figure 3-15. Space planning templates (top views)

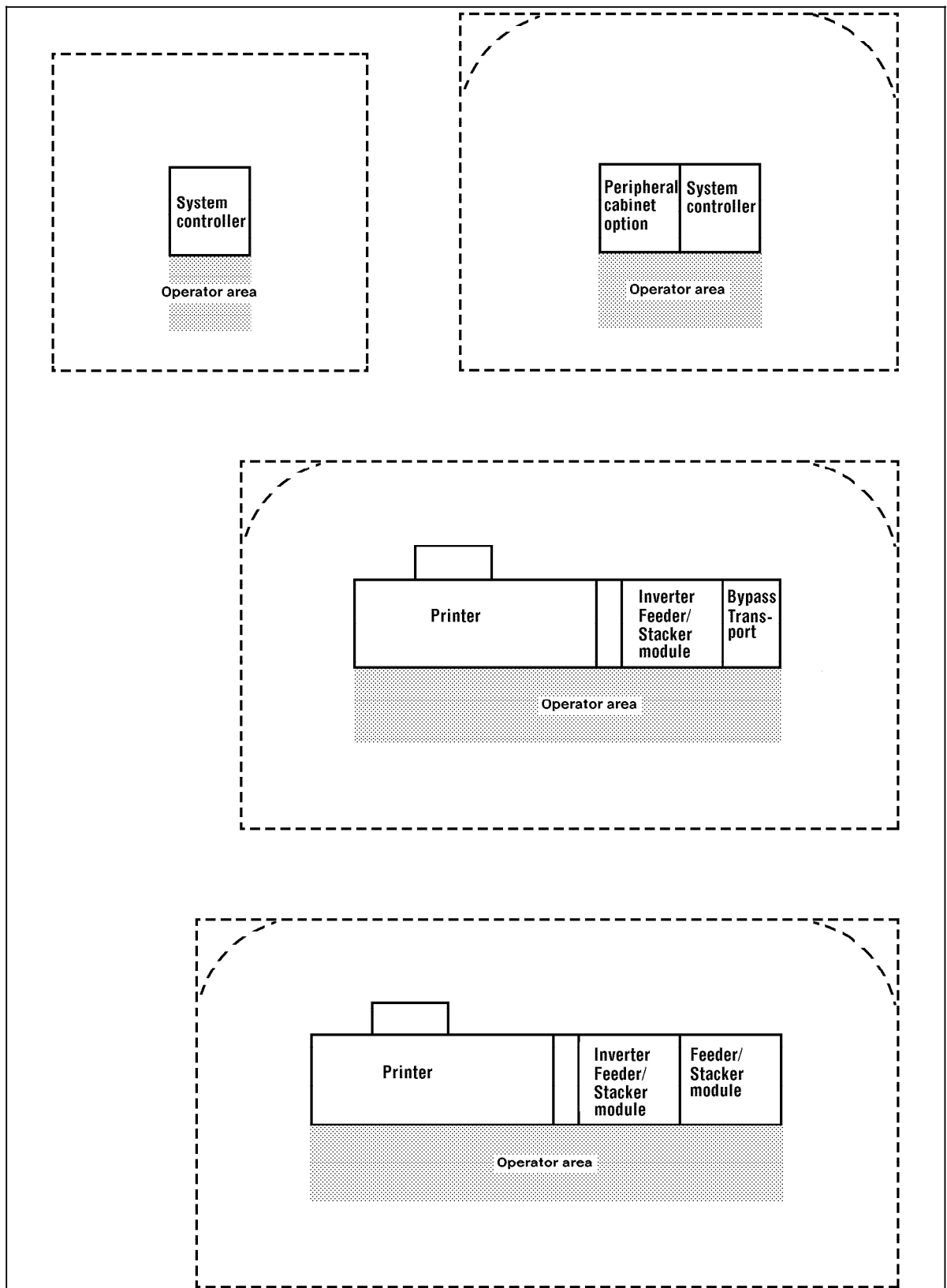

Figure 3-15. Space planning templates (continued)

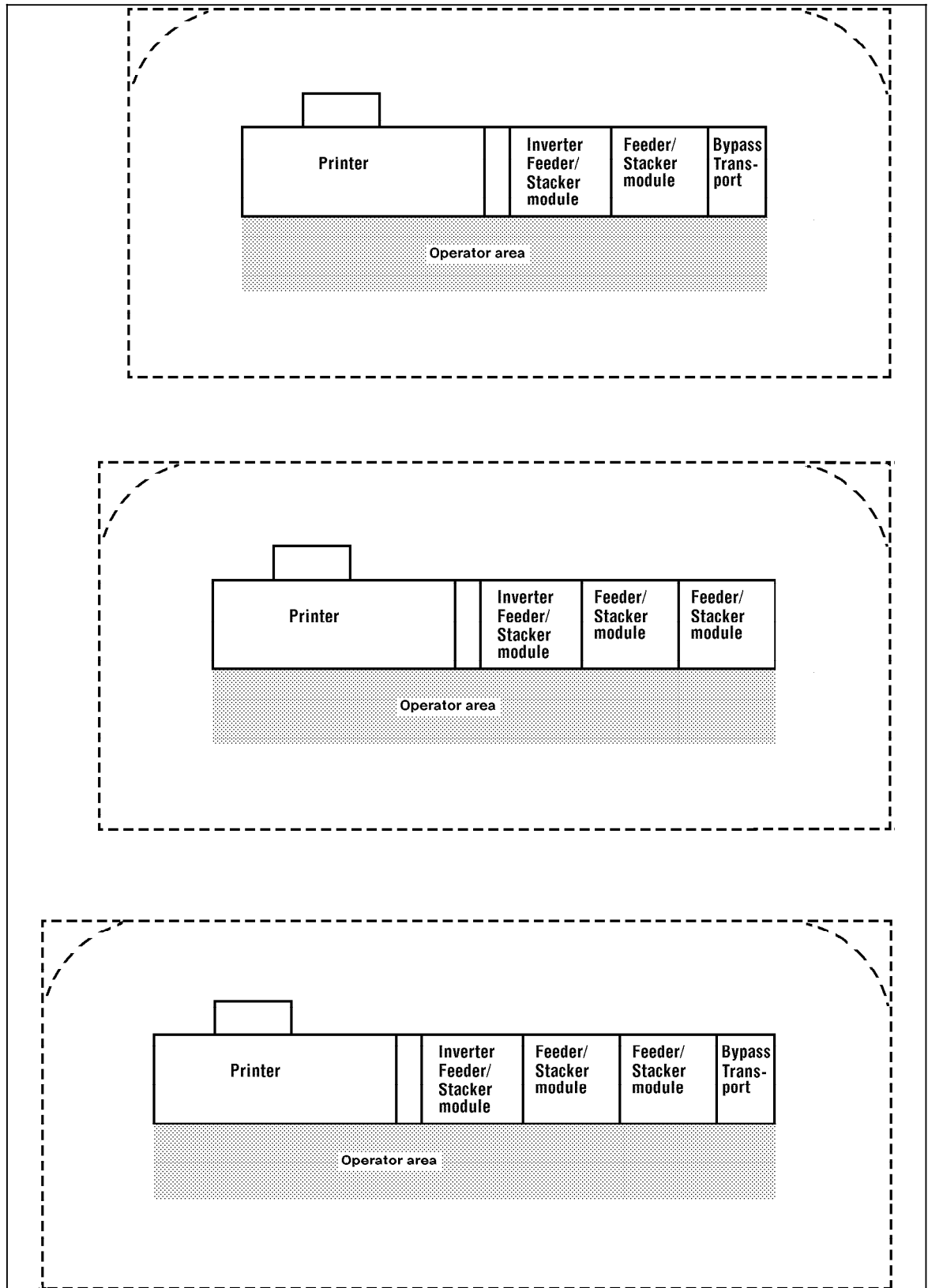
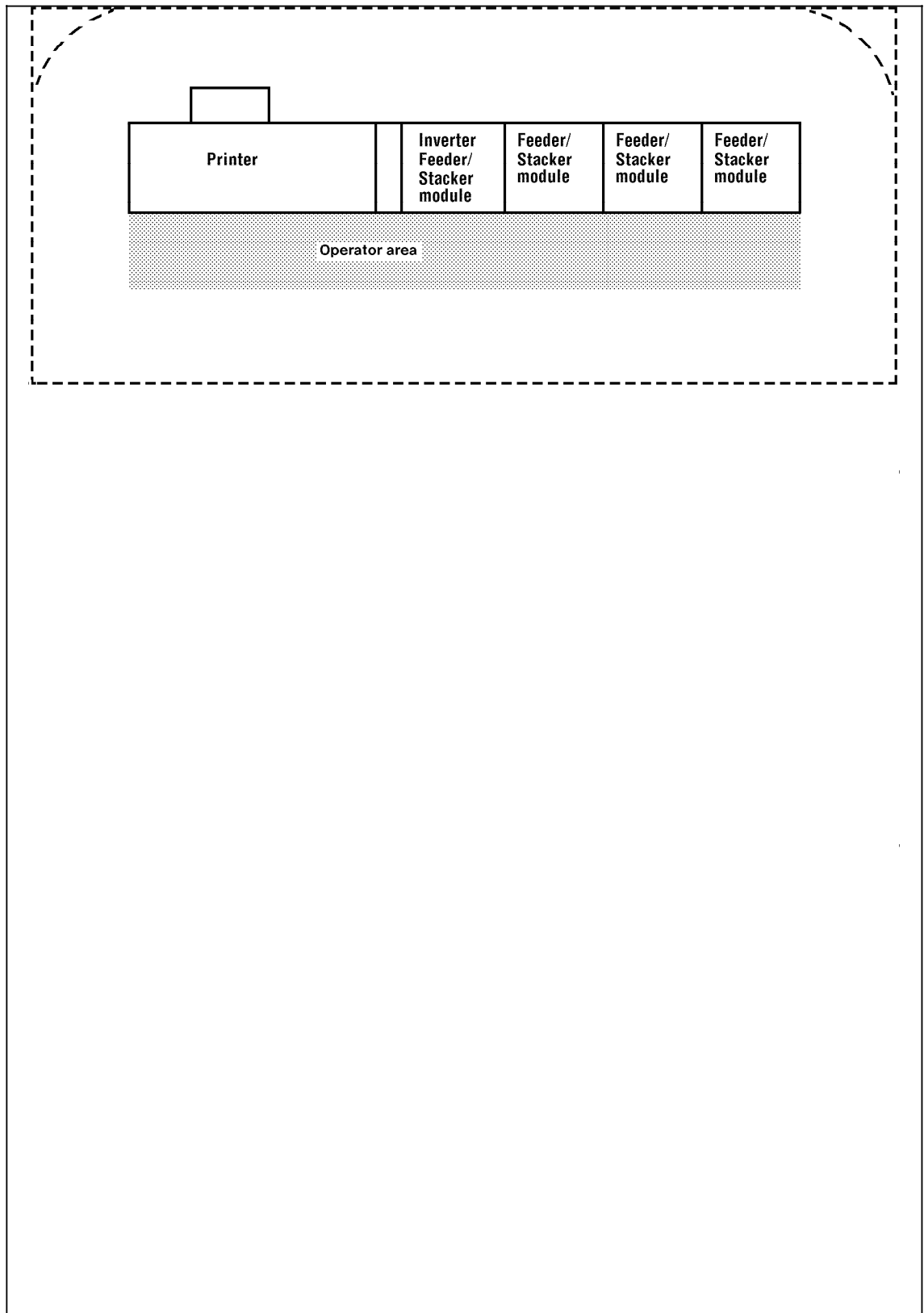

Figure 3-15. Space planning templates (continued)





# GRID PATTERN

1 square represents 1 foot/250 mm

1 2 3 4 5 6 7 8 9 10 11 12 13 14 15 16 17 18 19 20 21 22 23 24 25 26 27 28

C  
u  
t  
  
O  
n  
  
D  
o  
t  
t  
e  
d  
  
L  
i  
n  
e

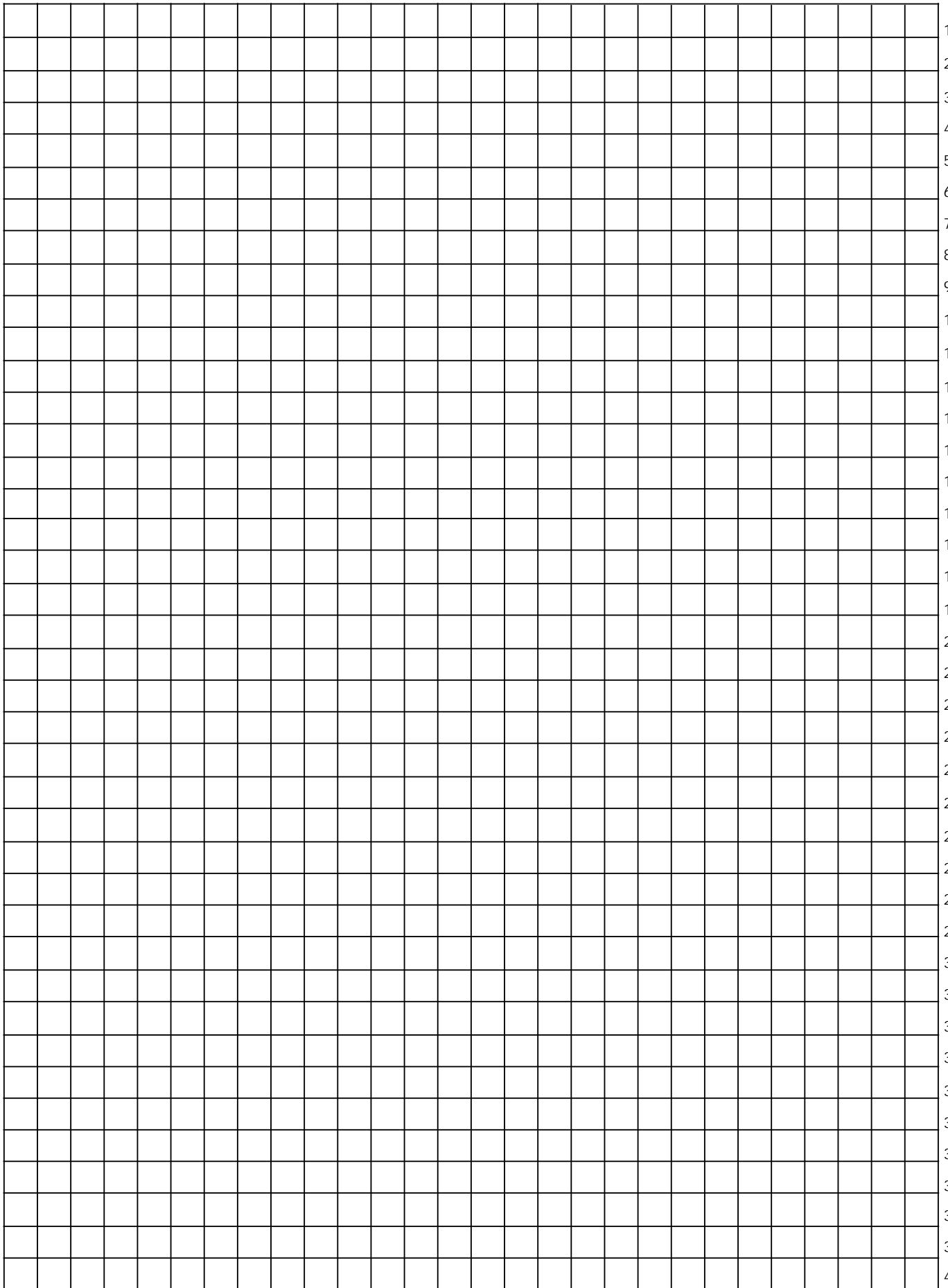



---

## The installation process

---

The installation process generally takes one to several days to complete. Equipment, software kits, and documentation kits may all arrive in one day or over the course of several days.

When all necessary items are in place, a team of Xerox or Rank Xerox personnel completes the installation of your LPS. Xerox installation responsibilities are shared by Xerox or Rank Xerox regional and customer engineers, sales and service representatives, and analysts.

The installation process typically occurs in the following order:

1. The equipment (hardware) and options are installed.
2. The LPS is sysgened and tested.
3. The system is placed online, if appropriate.
4. Initial applications are loaded and sample jobs are run.
5. Initial operator training is provided.

---

## Installation responsibilities

---

Xerox or Rank Xerox is responsible for the physical installation of the LPS components and the loading of software and applications. You have the more general site responsibility of ensuring that the right personnel and supplies are available. Installation responsibilities are outlined below. (Refer to the installation planning checklist in the introduction of this guide for a complete list of responsibilities.)

---

### Xerox or Rank Xerox responsibilities

---

Xerox or Rank Xerox is responsible for the following installation activities:

- Installing the 4635 LPS
- Loading the 4635 software and initial applications
- Training operators
- Reviewing preventative maintenance schedules and service call procedures.
- Physical installation of a LAN PWB into the PCUI and connection of the cable to the PWB if LAN option is used.
- Installation of Xerox developed software to support LAN.
- Verify system operation and audit log upload via LAN.

## Customer responsibilities

---

Customer responsibilities include the following:

- Ensure that all needed supplies are on site.
- Ensure that your system specialist is available during the loading of software and applications tapes.
- Have the appropriate operators available for training.
- Check the documentation and software kits for completeness.
- Have test jobs ready to run, if desired.

**Note:** If the customer has elected to use the LAN capability to upload audit logs to a remote system they are responsible for the following:

- Providing a LAN PWB plus all associated cables that meets the following requirements to the service rep for installation into the PCUI:
  - ethernet or token ring interface
  - software configurable or plug and play
  - FCC class B
  - UL standard 478 with a fire rating of 94V0 or 94V1
  - UL standard 1950
- Providing the log destination drive name and subdirectory to the service rep for system configuration.
- Connecting the LAN cable to the network.
- Loading the LAN PWB software.
- Operation and maintenance of the LAN including the LAN PWB installed in the PCUI.



---

## Documentation and software kits

---

When your basic software kits arrive, check their contents with the packing list or the appropriate list below to make sure you have received all appropriate items.

---

### Documentation

---

The documentation included in your basic LPS kit should contain the 4635 LPS Reference Set, which includes the following manuals:

- *Xerox 4635 Laser Printing System Operator Guide*
- *Xerox 4635 Laser Printing System Operations Reference*
- *Xerox 4635 Laser Printing System Sysgen Guide*
- *Xerox 4635 Laser Printing System Message Guide*
- *Xerox 4635 Laser Printing System PDL/DJDE Reference*
- *Xerox 4635 Laser Printing System Forms Creation Guide*
- *Xerox 4635 Laser Printing System Product Reference*
- *Xerox 4635 Laser Printing System Installation Planning Guide*
- *Xerox 4635 Laser Printing System Operator Command Summary Card*
- *Xerox 4635 Laser Printing System PC User Interface Reference*

If any items are missing, advise your Xerox or Rank Xerox sales representative or analyst, or call XDSS (refer to chapter 5, "Postinstallation").

As time permits, begin familiarizing yourself with the content and organization of the manuals. Begin with the 4635 Product Guide, as it provides an introduction to the 4635 LPS and directs you to other manuals when appropriate.

---

### Software kits

---

When you receive the software kits for the 4635 LPS and any software options you ordered, check the contents with the packing list. If items are missing, contact your Xerox or Rank Xerox sales representative immediately.



After the installation of your Xerox 4635 Laser Printing System (LPS), a number of ongoing tasks must be performed. These tasks may include all or some of the following:

- Maintaining an adequate inventory of consumable supplies
- Overseeing routine customer maintenance and meter reporting
- Arranging additional operator training
- Ordering additional fonts
- Placing service calls for hardware problems and obtaining assistance in solving application-related problems
- Identifying and implementing new applications.

As installation coordinator, it is your responsibility to designate a person (or persons) to perform these tasks.

This chapter describes these tasks and some of the Xerox support services available to you. There is also a consumable supplies table and a supplies checklist at the end of the chapter.

---

## Xerox support services

---

Xerox provides many services in support of your laser printing system. These services include the following:

- Xerox Customer Support Center
- Customer Service Support Center
- Xerox Font Center
- *Xerox Customer Documentation Catalog*
- Xerox Documentation and Software Services (XDSS)
- Xerox Supplies Order Service.

Detailed information about these services follows.

Prior to installation, your Xerox or Rank Xerox sales representative is available to answer your questions about the products, services, or billing. However, if you need assistance in resolving application-related problems or questions, contact your local Xerox or Rank Xerox systems analyst or call the Xerox Customer Support Center.

---

## Xerox Customer Support Center

---

The Xerox Customer Support Center is available to address your applications problems or to direct you to the appropriate documentation.

The key to effective use of the Xerox Customer Support Center is correct identification of the problem. Before calling the center, it is helpful to have the following information available:

- A list of any error messages
- An explanation of how output is different from what was expected
- Whether the symptoms follow a consistent pattern or occur randomly
- A list of special conditions that may have an effect on the system, such as:
  - New applications
  - Changes made to the host system software
  - Recent service performed on the LPS
  - Whether the application printed properly on the LPS prior to the problem.

The Xerox Customer Support Center telephone number is:

**1-310-333-2151 (nationwide), 5 a.m. to 5 p.m. Pacific time.**

## Customer Service Support Center

---

If you encounter software- or hardware-related problems, such as system failures, continuous paper jams, or poor print quality, first try the corrective actions described in your LPS operator guide. If the problem persists, call the Customer Service Support Center. Your site representative can provide you with the telephone number for the Customer Service Support Center in your area.

Before contacting Xerox or Rank Xerox service, please make note of the following:

- Status code numbers and messages which appear on the PC UI terminal, including the 6-digit code number that resulted from running the PROBLEM command
- Status messages which appear on the printer control console
- Indicator lights which may be lit
- Status codes which appear in the display window of the operator control panel if there is a tape drive problem. (Remember, you must perform Diagnostic Test 01 prior to placing a service call for a 9-track magnetic tape problem.)

Your call will be answered by a Xerox or Rank Xerox representative who will ask you for the following information:

- Your LPS model number: 4635
- The LPS serial number
- Your name
- Your company name
- Your work address
- Your company's work hours
- A contact name and telephone number within your company
- The system condition or status.

This information is given to a Xerox or Rank Xerox representative who will call you back to discuss the information and give you an

estimated time of arrival of a service representative, or assist you over the phone to resolve the problem.

---

## Xerox Font Center

---

The Xerox Font Center can send you samples and catalogs of the fonts available for your LPS.

To receive font samples, obtain price information, or to order licensed or custom fonts, call the font support center between 6:00 a.m. to 5:00 p.m. Pacific time at:

**1-800-445-FONT**

If you prefer, you may write to the following address to request font information:

Xerox Corporation  
Xerox Font Center ESCP-126  
701 South Aviation Boulevard  
El Segundo, CA 90245

For locations outside the United States, please contact your Xerox or Rank Xerox sales representative or local Xerox or Rank Xerox office.

For technical support regarding fonts (such as installing fonts or solving font-usage problems), call the Xerox Font Center at:

**1-800-521-8324**

---

## *Xerox Customer Documentation Catalog*

---

Detailed information on documentation for your LPS is contained in the *Xerox Customer Documentation Catalog*. The catalog includes a brief description of each item, its cost, and the instructions and forms needed for ordering.

Included at the back of this guide is a request card for ordering the *Xerox Customer Documentation Catalog*. Simply fill out the request card and mail it. Once you are on our mailing list, updated catalogs are sent to you automatically. You may also call Xerox Documentation and Software Services to request a catalog. (Refer to the following section.)

---

## Xerox Documentation and Software Services (XDSS)

---

Xerox Documentation and Software Services (XDSS) offer a variety of services that can be customized to meet your documentation needs.

XDSS distributes the documents you need to facilitate the installation and use of Xerox printers, workstations, and host-software packages. Site subscription is a free service that keeps these documents up to date by automatically sending you updates and revisions as they become available.

XDSS will also send you a *Xerox Customer Documentation Catalog* free of charge upon request. Forms for ordering documents, requesting a Customer Documentation Catalog, and registering for the site subscription service are provided at the back of this manual. Complete the forms or call:

**1-800-445-5554**, 6:00 a.m. to 5:00 p.m., Pacific time.

XDSS representatives will explain the services available, answer your questions, and take orders for documentation.

## Xerox Supplies Order Service

---

To avoid downtime, be sure always to have an adequate amount of the necessary supplies available. To do this, you need to establish a procedure for checking and ordering supplies. A supplies checklist is provided at the end of this chapter to help you with this task. It lists the supplies and contains a column for you to enter the date that the order should be placed and a column to write when the order actually was placed. The consumable supplies table, also located at the end of this chapter, contains a complete list of all Xerox supplies available for your LPS.

It is important that you check your supplies regularly and order before you run out. Plan on approximately five working days for delivery after the order has been placed. (Arrangements can be made to provide them sooner in emergency situations.)

Your Xerox or Rank Xerox sales representative can help you submit the initial order of supplies needed for installation. These items include paper, dry ink, fuser agent, and developer.

Once your printer's volume is established, planning ahead and buying Xerox supplies in quantity can save you money. Your Xerox supply specialists can help you.

There are two centers available to assist you:

- To order Xerox paper, transparencies, labels, dry ink, developer, fuser agent, and cartridge tape, call the following toll-free number weekdays between 7:30 a.m. and 6:00 p.m. Pacific time:

**1-800-822-2200 (U.S. only).**

If you prefer, you may mail orders to:

Xerox Corporation  
P. O. Box 25075  
Santa Ana, CA 92799-5075

- To order cleaning supplies, call the Xerox Parts Marketing Center weekdays between 5:00 a.m. and 5:00 p.m. Pacific time, at:

**1-800-828-5881 (U.S. only).**

You may also mail cleaning supplies orders to:

Xerox Corporation  
Parts Marketing Center  
Building 214-07S  
P. O. Box 1020  
Webster, NY 14580

Please provide the following information when placing orders:

- Your customer number (provided by your Xerox sales representative)
- Your LPS model: 4635
- Your supply order, including:
  - The item name

- The part number
- The quantity desired
- If your company requires a purchase order for payment of an invoice, you need to provide the purchase order number to Xerox at the time you place the order.

---

## Routine maintenance

---

There are a number of routine maintenance tasks that must be performed to ensure maximum efficiency of your LPS. These tasks include the following:

- Adding dry ink
- Cleaning the tape drives
- Cleaning the PC and the exterior surfaces of the system.

Step-by-step instructions on performing these routine maintenance tasks are contained in the *Xerox 4635 LPS Operator Guide*. You need to decide how many operators will be responsible for performing these maintenance tasks. Most maintenance procedures are covered in the initial operator training provided shortly after installation.

---

## Meter reading and reporting

---

As print jobs are processed, firmware in the printer or software in the system controller accumulates, saves, and maintains usage data in its nonvolatile memory.

Sometime during the last five working days of each month, that data needs to be reviewed and the information transmitted to Xerox for billing purposes. Refer to your *Xerox 4635 LPS Operator Guide* for complete instructions on how to report meter readings.

---

## Identifying new applications

---

Laser printing can be used for any application that requires immediate output and/or frequent updating. Following is a list of some applications for which laser printing is suited:

Forms	Service manuals
Proposals	Financial statements
Reports	Inventory reports
Price lists	Retail bar codes
Catalogs	Insurance policies
Invoices	Telephone directories
Statements	Personnel rosters
Newsletters	Labels
Legal briefs	Manuscript page proofs
Technical specifications	

This list is not all-inclusive but is intended to help you begin what should be an ongoing internal support process. At some point, you may want to check with all the departments within your organization to see which applications do (or will) apply to them.

## Consumable supplies table

Table 5-1 lists the supplies that are available from Xerox for your laser printing system. Use this table to help you determine your supplies needs.

Table 5-1. **Consumable supplies**

Item	Description	Part number
<b>Paper</b>	Xerox paper quantities are 10 reams (5,000 sheets) to a carton unless otherwise noted below.	
8.5" x 11"	4024 Dual Purpose Paper	3R721
A4	4024 Dual Purpose Paper	3R2594
8.5" x 14"	4024 Dual Purpose Paper	3R727
8.5" x 11"	4024 Dual Purpose Paper, 3-hole	3R723
8.5" x 11"	4024 Dual Purpose Paper, 3-hole*	3R2193
8.5" x 11"	4024 Dual Purpose Paper, 4-hole	3R1983
8.5" x 11"	4024 Dual Purpose Paper, 4-hole*	3R3008
8.5" x 11"	4024 Dual Purpose Paper, 7-hole	3R1984
8.5" x 11"	4024 Dual Purpose Paper, 7-hole*	3R3010
8.5" x 11"	4024 Smooth	3R2675
8.5" x 14"	4024 Smooth	3R2677
8.5" x 11"	Dual Purpose Colors, Blue	3R3052
8.5" x 11"	Dual Purpose Colors, Blue, 3-hole	3R3068
8.5" x 14"	Dual Purpose Colors, Blue, 3-hole	3R3084
8.5" x 11"	Dual Purpose Colors, Green	3R3056
8.5" x 11"	Dual Purpose Colors, Green, 3-hole	3R3072
8.5" x 14"	Dual Purpose Colors, Green	3R3088
8.5" x 11"	Dual Purpose Colors, Pink	3R3058
8.5" x 11"	Dual Purpose Colors, Pink, 3-hole	3R3074
8.5" x 14"	Dual Purpose Colors, Pink	3R3090
8.5" x 11"	Dual Purpose Colors, Yellow	3R3054
8.5" x 11"	Dual Purpose Colors, Yellow, 3-hole	3R3070
8.5" x 14"	Dual Purpose Colors, Yellow	3R3086
8.5" x 11"	Dual Purpose Colors, Buff	3R3060
8.5" x 11"	Dual Purpose Colors, Buff, 3-hole	3R3076
8.5" x 14"	Dual Purpose Colors, Buff	3R3092
8.5" x 11"	Dual Purpose Colors, Goldenrod	3R3062

\*5/16 inch drilled holes



Table 5-1. Consumable supplies (continued)

Item	Description	Part number
8.5" x 11"	4024 Dual Purpose Colors, Goldenrod, 3-hole	3R3078
8.5" x 14"	4024 Dual Purpose Colors, Goldenrod	3R3094
8.5" x 11"	4024 Dual Purpose Colors, Ivory	3R3064
8.5" x 11"	4024 Dual Purpose Colors, Ivory, 3-hole	3R3080
8.5" x 14"	4024 Dual Purpose Colors, Ivory	3R3096
8.5" x 11"	4024 Dual Purpose Colors, Gray	3R3066
8.5" x 11"	4024 Dual Purpose Colors, Gray, 3-hole	3R3802
8.5" x 14"	4024 Dual Purpose Colors, Gray	3R3098
8.5" x 11"***	4024 Dual Purpose Colors, Rainbow Pack (35,000 sheets/carton—250 sheets/pack)	3R3107
8.5" x 11"	10 Series Dual Purpose Paper	3R2950
8.5" x 11"	10 Series Dual Purpose Paper, 3-hole	3R2952
8.5" x 11"	10 Series Dual Purpose Paper, 3-hole*	3R3016
8.5" x 14"	10 Series Dual Purpose Paper	3R2954
8.5" x 11"	10 Series Smooth	3R54
8.5" x 14"	10 Series Smooth	3R83
8.5" x 11"	4024 Dual Purpose, reinforced 3-hole	3R2057
9.5" x 11"	65-pound divider white (2,500 sheets/carton)	3R3428
11" x 17"	4024 Dual Purpose Paper (2,500 sheets/carton)	3R729
	4024 Dual Purpose Paper, 7-hole*	3R3074
<b>Transparencies</b>	Xerox transparencies are packaged 100 sheets to a box.	
8.5" x 11"	Clear, with a white strip on the edge	3R2780
	Clear, High Speed, paper backed	3R3028
<b>High Speed Labels (Gummed)</b>	Xerox labels are packaged 1,000 sheets to a box.	
8.5" x 11"	33 labels per sheet	3R3139
8.5" x 11"	6 labels per sheet	3R3146
8.5" x 11"	Custom form (uncut)	Contact Xerox Supplies Service
8.5" x 11"	1-up label	3R4476
8.5" x 11"	1-up label	3R4475
8.5" x 11"	1-up label	3R4474

\*\*\*Rainbow pack contains 750 sheets each of blue and yellow, 500 sheets each of green and pick, and 250 sheets each of buff, gray, goldenrod, and ivory.

Table 5-1. Consumable supplies (continued)

Item	Description	Part number
<b>Tab stock</b>	Xerox tab stock is packaged in 5-tab sets. 250 sheets/carton.	
	Straight collated singles (forward, top down)	
	— Non-drilled 90-pound, Index white	3R4417
	— Non-drilled 90-pound, blue	3R4425
	— Three-hole 90-pound, Index white	3R4418
	— Three-hole 90-pound, blue	3R4426
	Reverse collated singles (bottom up)	
	— Non-drilled 90-pound, Index white	3R4415
	— Three-hole 90-pound, Index white	3R4416
<b>Cover stock</b>	Xerox cover stock is packaged 2,500 sheets/carton.	
	8.5" x 11" 65-pound, blue	3R3044
	8.5" x 11" 65-pound, white	3R3041
<b>Dry ink</b>	Packaged 3 cartridges/carton. (Consumption rate is approximately one cartridge per 60,000 pages.)	6R819
<b>Dry Ink Waste Bottle</b>		93K460
<b>Developer</b>	Packaged 2 bottles/carton. (Effective life is approximately one carton per 600,000 pages.)	5R573
<b>Fuser agent</b>	Packaged 1 bottle. (Consumption rate is approximately one bottle per 250,000 pages.)	8R4077
<b>Cleaning supplies</b>	Magnetic Head Cleaning Kit. Packaged 2 diskettes per box.	8R2463
	Hub and Transport Cleaner	99P87486
	Foam-tipped swabs	99P87256
	Lint-free towels	35P2163
	18-track cleaning cartridge	8R3635
<b>Cartridge Tape</b>	QIC (1/4-inch) blank cartridge, 320 MB	9R84168

Table 5-1. Consumable supplies (continued)

Item	#of parts	Sequence	Sheets	Sheets per carton	Sets per carton	Cartons per pallet	Part number
<b>Carbonless stock</b> <b>8.5" x 11"</b> ***	2	Reverse/ Straight	Alternating CB-White CF-Canary	5000	2500	40	3R4225
	2	Straight/ Double	Alternating CB-White CB-White CF-Canary CF-Canary	5000	2500	40	3R4226
	2	Reverse/ Straight	Alternating CB-White CF-Pink	5000	2500	40	3R4227
	3	Straight	Alternating CB-White CFB-Canary	5010	1670	40	3R4230
	3	Straight/ Double	Alternating CB-White CB-White CFB-Canary CFB-Canary CF-Pink CF-Pink	5010	1670	40	3R4231
	4	Straight	Alternating CB-White CFB-Canary CFB-Pink CF-Goldenrod	5000	1250	40	3R4235
	N/A	N/A	CB-White	5000	N/A	40	3R4236
	N/A	N/A	CFB-White	5000	N/A	40	3R4238
	N/A	N/A	CFB-Canary	5000	N/A	40	3R4239
	N/A	N/A	CFB-Pink	5000	N/A	40	3R4240
	N/A	N/A	CF-White	5000	N/A	40	3R4242
	N/A	N/A	CF-Canary	5000	N/A	40	3R4243
	N/A	N/A	CF-Pink	5000	N/A	40	3R4244
	N/A	N/A	CF-Goldenrod	5000	N/A	40	3R4245

\*\*\* All papers are packaged 500 sheets per ream, with 10 reams per carton. Each ream contains only complete carbonless sets (i.e., 501 sheets in a three-part ream for 167 sets).

Table 5-1. Consumable supplies (continued)

Item	#of parts	Sequence	Sheets	Sheets per carton	Sets per carton	Cartons per pallet	Part number
<b>Carbonless stock</b> <b>8.5" x 14"</b> ****	2	Reverse/ Straight	Alternating CB-White CF-Canary	5000	2500	30	3R4228
	3	Straight	Alternating CB-White CFB-Canary CF-Pink	5010	1670	30	3R4233
	N/A	N/A	CB-White	5000	N/A	30	3R4237
	N/A	N/A	CFB-Canary	5000	N/A	30	3R4241
	N/A	N/A	CF-Canary	5000	N/A	30	3R4246
	N/A	N/A	CF-Pink	5000	N/A	30	3R4247

\*\*\*\* All papers are packaged 500 sheets per ream, with 10 reams per carton. Each ream contains only complete carbonless sets (i.e., 501 sheets in a three-part ream for 167 sets).

Figure 5-1. **Supplies checklist**

<b>Supplies checklist</b>				
Use this checklist to help record the supplies and accessories you require, the date you plan to place the order, and the actual date of the order.				
<b>Item</b>	<b>Description</b>	<b>Quantity</b>	<b>Date to order</b>	<b>Date ordered</b>
<b>Paper</b>				
<b>Dry ink</b>				
<b>Developer</b>				
<b>Fuser agent</b>				
<b>Labels</b>				
<b>Transparencies</b>				
<b>Cartridge tapes</b>				
<b>Cleaning supplies</b>				



<b>A3</b>	Paper size measuring 297 by 420 mm.
<b>A4</b>	Paper size measuring 210 by 297 mm.
<b>abort</b>	To terminate the printing of a job or execution of a program before it completes.
<b>algorithm</b>	Computational procedure that can be repeated any number of times.
<b>alignment</b>	Positioning of an image on a page for printing.
<b>alphanumeric</b>	Set of characters including the letters A through Z, numerals 0 through 9, and all printable special symbols.
<b>ASCII</b>	American Standard Code for Information Interchange. Standard 7-bit code that represents alphanumeric information. Each alphanumeric character and several nonprinting characters are assigned a binary number, covering 128 possible characters. It is used for information interchange among data processing systems, data communication systems, and associated equipment.
<b>application</b>	Use to which a computer program or system is put, for example, sorting employee records.
<b>applications software</b>	Host- or LPS-resident software that directs the computer to perform specific tasks or functions as opposed to the software used to operate the computer. Common business applications include payroll, accounting, and inventory.
<b>asynchronous</b>	Transmission in data communications controlled by start and stop elements at the beginning and end of each character. Thus, time intervals between transmitted characters may be unequal in length.
<b>B4</b>	Paper size measuring 250 by 353 mm.
<b>B5</b>	Paper size measuring 182 by 257 mm.
<b>background job</b>	Low-priority job, usually batched, that is executed automatically as system resources become available.

<b>backup file</b>	File copied to a storage medium for safekeeping in case the original is damaged or lost.
<b>bar code</b>	A font, form, or logo that serves as a unique page identifier. Bar codes help track and monitor individual pages in a given job to ensure that they print correctly.
<b>bar code reader</b>	A device which, with associated software, detects the presence of bar code information on a page.
<b>batch</b>	Processing method that accumulates execution tasks.
<b>batch processing</b>	Allows for repetitive operations to be performed sequentially on batched data without much involvement of the computer operator.
<b>baud</b>	Measurement of data rate in bits per second. This term is used to describe information flow between two devices. Unit of data transmitting and receiving speed is roughly equal to a single bit per second. Common baud rates are 110, 300, 1200, 2400, 4800, and 9600.
<b>binary</b>	Numbering system based on 2 that uses only the symbols 0 and 1. Binary is used in computers and related devices since information can be represented with electric pulses (0=off, 1=on). Most computer calculations are binary.
<b>bit</b>	Abbreviation for binary digit, the smallest unit of information recognized by a computer.
<b>bit map</b>	Visual representation of graphic images in which a bit defines a picture element (pixel); for example, if a bit is 1, the corresponding pixel is printed.
<b>bit mapped</b>	Display image generated bit by bit for each point or dot. A software-driven scanner is used to create characters or graphics.
<b>boot</b>	To load the initial instructions of a program into computer memory; these instructions then direct the loading of the rest of the program. Booting may require entry of a few commands at the keyboard or the flip of a switch to begin the process.
<b>bps</b>	bits per second. In serial communication, the instantaneous bit speed with which a device or channel transmits a character.
<b>BSC</b>	binary synchronous communication. 1. Communication using binary synchronous line discipline. 2. Uniform procedure using a standardized set of control characters and control character sequences for synchronous transmission of binary-coded data between stations.



---

<b>Bypass Transport</b>	Optional module that moves paper from the last stacker bin to a finishing device.
<b>byte</b>	Fixed number of bits (in data processing, usually 8) operated upon as a unit. A byte may represent a character, a machine instruction, or some other logical unit of information.
<b>carriage return</b>	Control character that causes the printing system to start printing at the left margin of the current line unless set to be interpreted as a line end.
<b>channel</b>	1. In data communications, a path or line that enables two or more devices to communicate (sometimes called a circuit, facility, or link). 2. In computers, a path for communication between the central processing unit (CPU) and input/output units, or between the CPU and peripheral devices.
<b>character</b>	Single printable letter (A-Z), numeral (0-9), symbol (& % #), or punctuation mark ( , . ! ?) used to represent data. Characters can also be nonprinting, such as space, tab, or carriage return.
<b>character set</b>	Number of different characters used by a particular device, including alphabetic, numeric, and special characters such as symbols.
<b>CME</b>	copy modification entry. Entry modifying the output printing characteristics of a report on a copy-to-copy basis.
<b>code</b>	1. Set of symbols representing data or instructions to a computer. 2. To write a list of instructions (software) to cause the product/system to perform specified operations.
<b>code conversion</b>	Translation of one type of character or symbol code to another.
<b>collate</b>	To arrange or assemble into ordered sets.
<b>column</b>	Vertical arrangement of characters.
<b>command</b>	User instruction to a computer, using the system controller keyboard or the PC UI. Commands are words, mnemonics, or characters that cause a computer to perform predefined operations. Coded instruction to a computer or computer-based system.
<b>command language</b>	Set of commands that can be used for a system, such as how the system can be instructed to perform a task.
<b>communication line</b>	Telecommunication line connecting devices at one location with devices at other locations in order to transmit and receive information.

<b>communication link</b>	Physical means, such as data link, connecting one location to another to transmit and receive information.
<b>communications</b>	Ability of two devices to transmit information to each other.
<b>compatibility</b>	Characteristic of computer equipment permitting one device to use the same information or programs as another device without conversion or code modification.
<b>compiler</b>	Software that translates instructions written in high-level language into machine language for execution by a system.
<b>computer</b>	Functional unit capable of performing substantial computations, including numerous arithmetic or logic operations without human intervention during a run.
<b>computer language</b>	Computer-oriented language consisting solely of computer instructions. See also <i>machine language</i> .
<b>computer program</b>	Sequence of instructions suitable for processing by a computer.
<b>computer system</b>	Central processing unit (CPU) with main storage, input/output channels and devices, control units, and external storage devices connected to it.
<b>configuration</b>	One or a group of computers and related devices, such as terminals and printers, interconnected and programmed to operate as a system (sharing resources, communicating data, accepting input, and so on).
<b>console</b>	Functional unit containing devices used by an operator to communicate with an operating system. It may consist of a display, keyboard, and certain switches or other controls.
<b>consumable supplies</b>	Supplies such as paper and dry ink that are depleted (used up) during the course of normal printer operation.
<b>continuous printing</b>	Refers to Interpress job integrity under any of the following conditions: excessive graphics, forms, or font use problems.
<b>control program</b>	Program that supports the operating system by monitoring the flow of jobs, tasks, processing, and so on, within the system; for example, a data communication program.
<b>coordinate</b>	Point on the x and y axis that determines a grid position.
<b>copy</b>	To duplicate data in a new location or on an additional storage medium, for example, to copy files from disk to tape.
<b>cpi</b>	characters per inch. Designates the number of characters per inch for a particular typeface. See also <i>pitch</i> .

---

<b>CPU</b>	central processing unit. Interprets and executes instructions, performs all operations and calculations, and controls input and output units and auxiliary attachments.
<b>data</b>	1. In general, facts, numbers, letters, symbols, and so on, which can be processed or produced by a computer. 2. In data processing, the source data or raw data entered for processing, as opposed to the results obtained by processing.
<b>database</b>	Information to meet specific processing and retrieval needs. Generally applies to integrated file of data, arranged for access by many subsystems.
<b>data communications</b>	Transmission and reception of encoded information over telecommunication lines.
<b>data link</b>	Physical means of connecting one location with another for communication, such as the communications lines, modems, and controls which transmit information between two or more stations.
<b>data processing</b>	Operations carried out on data by means of algorithms and programs to produce information or a specific result. The rearrangement of data into a suitable form for further use.
<b>data storage</b>	Preservation of data on various media, for example, tape, disks, magnetic bubble memory, and so on.
<b>data transmission</b>	Transmission of coded data over telephone or other telecommunication lines.
<b>debug</b>	To detect and correct errors in a program.
<b>decompose</b>	To break down into component parts, such as when Interpress breaks down a Font Interchange Standard (FIS) master to compile font information.
<b>default</b>	Value assigned to a field by the system. Default fields may be used for such items as document formats, menu selections, input fields, font selection, and paper or image size. The default value of a field may be changed.
<b>desktop</b>	Basic display screen of the PC UI.
<b>device</b>	Any piece of hardware other than the central processing unit (CPU).
<b>digitize</b>	To express or represent data in digital (binary) form so that it can be processed electronically.
<b>disk drive</b>	Device that can read or write magnetic media.

<b>display</b>	Viewing device (monitor) that visually communicates system warnings, status, and error messages and reflects operator interaction with the system on a display.
<b>DJDE</b>	Dynamic Job Descriptor Entry. Command within an input data stream used to modify the printing environment dynamically.
<b>document</b>	1. Data medium and the data recorded on it, usually permanent, which can be read by you or a computer. 2. Collection of information pertaining to a specific subject or related subjects.
<b>dot</b>	Unit of measurement representing a fraction of an inch, for example, 300 dots per inch (dpi). It may also be referred to as a picture element (pixel) or spot.
<b>download</b>	To copy files using communication lines from the host onto LPS system disks.
<b>dry ink</b>	Minute dry particles of resin and carbon black used to create images. Dry ink can accept an electrical charge.
<b>duplex</b>	Ability to send and receive information simultaneously. See also <i>simplex printing</i> .
<b>duplex printing</b>	Printing on both sides (front and back) of a page. See also <i>simplex printing</i> .
<b>EBCDIC</b>	extended binary coded decimal interchange code. Coded character set consisting of 8-bit coded characters. It can accommodate 256 characters.
<b>edgemarking</b>	Use of graphic objects, usually lines or boxes, that bleed off the edge of the physical page. See also <i>physical page</i> .
<b>electronic publishing</b>	Integrated production of documents on demand, using digitally stored documents, computerized composition, and electronic printing systems.
<b>enabler</b>	Hardware devices or software packages that allow the printer to perform in a specified manner.
<b>escapement</b>	Lateral positioning of characters or font families.
<b>Ethernet</b>	Xerox local area network (LAN) that allows data to be transmitted by cable from one device to another, enabling it to share the network.
<b>FDL</b>	forms description language. LPS-resident source language used for designing electronic forms. See also <i>form</i> ; <i>FSL</i> .

---

<b>feedback</b>	Portion of an output signal that is returned, directly or indirectly, to be compared to a reference signal to maintain the quality of an output signal.
<b>file</b>	Set of records or text that can be stored and retrieved. An organized, named collection of records treated as a unit. For offline, it is the data between the two tape marks. For online, it is the data between banner pages.
<b>file maintenance</b>	To keep a file up to date by regularly adding, changing, or deleting data.
<b>file protection</b>	To prevent the contents on a disk or tape from being erased or written over by disabling the write head of a unit.
<b>file purging</b>	To erase the contents of old files to make room for new data.
<b>firmware</b>	Permanent programs stored in read-only memory (ROM).
<b>FIS</b>	Font Interchange Standard. Standard that defines the digital representation of fonts and character metrics for the generation of an entire series of Interpress fonts.
<b>fixed font</b>	Font containing characters with fixed spacing. See also <i>proportional font</i> .
<b>fixed pitch</b>	Font set in which every character cell has the same width. In reference to character sets, this term describes typefaces in which all character cells are of equal width. Monospaced as opposed to proportional spaced.
<b>fixed spacing</b>	Arrangement of characters on a line so that all characters occupy the same amount of horizontal space.
<b>flag</b>	Small indicator marking the occurrence of an event or the existence of a certain condition while the program is executing.
<b>font</b>	Set of images, usually characters and symbols, having common characteristics such as style, width, height, and weight.
<b>form</b>	1. Compiled forms source library (.FSL) file. 2. Printed or typed document with blank spaces for inserting information. Specific arrangement of lines, text, and graphics stored in a computer under an identifying name. Page of data that, when preceded by proper commands, is stored on the system disk as a permanent file. It may be merged with variable data by a form start command. See also <i>FDL; FSL</i> .
<b>format</b>	1. Layout of a document, including margins, page length, line spacing, typeface, and so on. 2. In data storage, the way the surface of a disk is organized to store data. 3. To prepare the surface of a disk for acceptance of data.

<b>FSL</b>	forms source library. Uncompiled collection of user-created files containing FDL commands. See also <i>FDL</i> ; <i>form</i> .
<b>function keys</b>	Keyboard keys that produce no character but initiate a particular machine function, such as delete.
<b>fuse</b>	To affix dry ink to paper by heat or pressure or a combination of both.
<b>GCR</b>	group code recording mode. Refers to the specific density of data (such as 6250 bpi) as it is recorded on tape, which is measured in bits per inch (bpi).
<b>graphics</b>	Use of lines and figures to display data, as opposed to using text.
<b>grid</b>	Imaginary pattern of evenly spaced horizontal and vertical lines on a page.
<b>grid unit</b>	Smallest rectangle enclosed by horizontal and vertical lines on a grid. The size of a grid unit is expressed as the length of one side of a rectangle.
<b>halftone screen</b>	A tool used in offset printing, typesetting, and laser printing to convert a continuous tone (such as photographic) image to dots, which allows the image to be rendered accurately in these printing processes.
<b>hardcopy</b>	Machine output in permanent form, such as printed reports, listings, and so on. Output in a permanent form (usually on paper or paper tape) rather than in temporary form, as on a display. Contains readable printed copy of machine (for example, computer) output.
<b>hardware</b>	Physical components, such as mechanical, magnetic, and electronic elements of a system, as opposed to programs, procedures, rules, and associated documentation. Hardware is operated by software and firmware.
<b>HCF</b>	high-capacity feeder. Feeder tray capable of holding 2500 sheets of 20 pound/75 gsm paper. The high-capacity feeder trays are the primary paper supply for the 4635 LPS. They are located in the bottom half of the feeder/stacker modules.
<b>HCS</b>	high-capacity stacker. Stacker bin capable of holding 2500 sheets of 20 pound/75 gsm paper. In the 4635 LPS, the high-capacity stacker bins are located in the top half of the feeder/stacker modules.
<b>hierarchy</b>	Relative priority assigned to arithmetic or logical operations that must be performed.

---

<b>high-level language</b>	Language consisting of words and symbols that are close to normal English and, therefore, readily understandable by the user. High-level languages are oriented to problems or commercial procedures and are the source languages for most programs.
<b>host</b>	Computer accessed by users which serves as a source of high-speed data processing for workstations with less computer power. See also <i>mainframe</i> .
<b>host interface</b>	Connection between network and host computer.
<b>icon</b>	Symbol appearing on the PC UI or printer control console that can be opened to display a window or screen options.
<b>image area</b>	Area on a physical page that may contain text or graphics.
<b>implementation</b>	Process of installing hardware or software to a system. Also the process of converting a design into an actual working system.
<b>information processing</b>	Generic term encompassing both word and data processing, used to describe the entire scope of operations performed by a computer.
<b>initialize</b>	1. To prepare the magnetic surface of a blank diskette so that it can accept data. 2. To set all information in a computer system to its starting values (usually the first step is accomplished when a program is booted).
<b>input</b>	Data or text introduced into a computer-based system.
<b>input devices</b>	Keyboards, magnetic media, or any device used to give a system information.
<b>input/output</b>	General term encompassing the flow of data into and out of a system.
<b>input processing</b>	Formatting control for the pages of a report.
<b>insert</b>	To add text or graphics to a document.
<b>interface</b>	Device by which two systems connect and communicate with each other.
<b>interpolation</b>	Series of logical rules implemented in the printer to convert a 300 spi input video stream to a 600 spi output video stream. Interpolation is functionally analogous to bit doubling (2x scaling), except the logical rules result in superior output.
<b>Interpress</b>	Xerox standard that defines digital representation of lines for printing. Interpress documents can be printed on any sufficiently powerful printer equipped with Interpress print software.

<b>Interpress font utility (IFU) program</b>	Program used to convert FIS fonts to LPS fonts.
<b>Interpress master</b>	File written according to the Interpress standard.
<b>JDE</b>	job descriptor entry. Collection of job descriptions. See also <i>job</i> ; <i>JSL</i> .
<b>JDL</b>	job descriptor library. Collection of compiled job descriptions. See also <i>JSL</i> .
<b>job</b>	1. Set of instructions (JDEs) defining a unit of work for the system. 2. In setting a separation boundary through the Bin Full Criteria task, job refers to everything printed as the result of a single start command. See also <i>JDE</i> .
<b>job control</b>	Program called into storage to prepare each job or job step to be run.
<b>job management</b>	Collective functions of job scheduling and command processing.
<b>JSL</b>	job source library. Collection of uncompiled job descriptions. See also <i>JDE</i> ; <i>JDL</i> ; <i>job</i> .
<b>keyboard</b>	Group of alphabetic, numeric, and/or function keys used to enter information into a system.
<b>label</b>	1. In data storage, a reference to a file saved on tape or disk, a record indicating the file name or date created, or other control information. 2. In programming, a name assigned to a particular instruction or portion of a program as a locational reference (the computer translates the label into an address).
<b>landscape page orientation</b>	Orientation of print lines or top of an illustration parallel to the long edge of the paper if the sheet is within the standard size range. (Sheets larger than standard have the reverse print orientation.)
<b>language</b>	Defined set of characters and symbols combined together by specific rules. See also <i>high-level language</i> ; <i>low-level language</i> .
<b>laser printing</b>	Technology that uses a laser to transfer character forms to a page by direct or indirect means.
<b>latent image</b>	Static charge present on the photoconductor before contact with dry ink particles.
<b>LED</b>	light emitting diode. Solid substance that glows when a current is passed through it. Often used for indicator lights on disk drives or modems, as well as for displays on other electronic equipment.



---

<b>LEF</b>	long-edge feed. The movement of paper through the printer in the direction of the paper length (the longer side of a sheet of paper).
<b>legal size</b>	Sheet the standard size of legal briefs, 8.5 by 14 inches.
<b>letter size</b>	Paper sized 8.5 by 11 inches/216 by 279 mm.
<b>library</b>	In data storage, a collection of related files or programs.
<b>line</b>	One horizontal flow of characters.
<b>line printer</b>	High-speed printer that prints an entire line of characters at one time.
<b>link</b>	Line connecting two or more intelligent terminals or nodes in a network.
<b>listing</b>	Printout or display of the statements in a program, usually used as a convenience in examining or editing programs.
<b>load</b>	To enter data into storage or working registers.
<b>location</b>	Place in which data can be stored.
<b>log</b>	Collection of messages or message segments placed on an auxiliary storage device for accounting or data collection purposes.
<b>logical page</b>	In the Xerox printing systems environment, a formatted page that is smaller than the physical page. A logical page is defined by an origin, thus allowing more than one logical page to be placed on a physical page.
<b>logo</b>	Small illustration or design, usually simple, typically used to identify a company.
<b>log off</b>	Procedure by which a user ends a session.
<b>log on</b>	Procedure by which a user begins a session between an application program and a logical unit.
<b>low-level language</b>	Language that is close to machine language so that each written instruction in a program can be converted to machine language on a one-to-one basis.
<b>machine language</b>	Binary code that can be read directly by a computer's central processing unit (CPU). All programming languages are eventually broken down into machine language for execution by the computer. See also <i>computer language</i> .

<b>magnetic media</b>	Term for all storage devices, such as disks, diskettes, and tape, on which data is stored in the form of magnetized spots on surface of the media.
<b>magnetic storage</b>	Use of magnetic media to store data, programs, and so on.
<b>magnetic tape</b>	Flexible plastic tape, with one side offering a magnetic surface suitable for storing computer data in the form of magnetized spots. Magnetic tape is often used for long-term storage since it can accommodate large volumes of information.
<b>mainframe</b>	Central processing unit (CPU) and memory of a large computer. More often used to denote any large computer of the type that might be used to control a group of smaller computers, terminals, or other devices. See also <i>host</i> .
<b>margins</b>	White space on each side of printed text.
<b>master file</b>	File serving as a general reference point for a particular application system. Provides information to be used by the program. It is usually updated and maintained to reflect the results of current or daily processing operations.
<b>MB</b>	megabyte. Unit of one million bytes.
<b>media</b>	Vehicles or devices by which information is stored or transmitted. Classifications include source, input, and output.
<b>medium</b>	Object or material on which data is stored, for example, magnetic tape or floppy disk.
<b>memory</b>	Space in a device where information is kept, or the ability of a device to keep information until needed.
<b>menu</b>	List of available functions, commands, and options.
<b>merge</b>	Operation combining two or more files into one predetermined order. For example, to merge two separate, alphabetically ordered files of names would result in one large alphabetically ordered file.
<b>message</b>	Unit of information transmitted by one facility to another in a form that the receiving facility can understand and act upon. The standard message format consists of a header (containing identifying and control information), followed by the actual message content, followed by a trailer (indicating that the message is completed).

---

<b>metacode</b>	Same as "native mode." The method of speaking to and controlling the image generator. These controls are used by the character dispatcher to generate scan line information. This information is sent in the form of character specifications to the image generator, which uses it to compose the bit stream that modulates the laser.
<b>MHz</b>	megahertz. 1. Unit of cycling speed (one million cycles per second) for an electromagnetic wave (in particular, a radio wave). 2. Sending and receiving stations of a radio wave transmission must be tuned in to the same unit of megahertz.
<b>MICR</b>	Magnetic Ink Character Recognition. MICR allows a computer to read characters printed in special metallic ink by scanning the shapes of their magnetic fields. MICR fields are often imprinted on bank checks before processing.
<b>mixed environment</b>	Multiple Xerox printers or printing systems (for example, 9790 and 4090 printers) in the same location.
<b>mode</b>	Manner in which an activity or process is carried out.
<b>modem</b>	Device that converts digital information into an analog signal suitable for sending over analog telecommunication lines. Also converts an analog signal from telecommunication lines into digital information.
<b>module</b>	Cohesive unit within a program. It is consistent in its level and identifiable in terms of loading or with other units.
<b>monitor</b>	Program used to supervise, control, or verify the operations of a system.
<b>mouse</b>	Electronic device used with the PC UI to select options and enter data.
<b>mouse pad</b>	Base that provides friction and direction information to the electronic mouse.
<b>mouse tray</b>	Optional extension module attached to the system controller to accommodate the mouse pad and provide ample working space.
<b>network</b>	1. System of geographically separate computers, linked to one another over transmission lines. 2. Communication lines connecting a computer to its remote terminals.
<b>node</b>	Station, terminal, or computer that performs some control operation and influences the operation of the network as a whole.
<b>nonimpact printer</b>	Printer that forms characters without any strikes of a key or element against the paper.

<b>object file</b>	Source file converted into machine language (binary code).
<b>object mode</b>	For the 4635 LPS, the processing method of the PC UI which uses the mouse, windows, and icons. The PC UI operates in either the object mode or in the terminal emulation mode (TEM). See also <i>TEM</i> .
<b>offline</b>	Devices not under the active control of a central processing unit. For example, a computer makes output to a magnetic tape. The tape is then used by an offline printing system to produce printed data. Offline operations are much slower than online operations. See also <i>online</i> .
<b>offset</b>	To place pages currently being printed in slightly different positions from previous pages.
<b>offset printing</b>	Widely-used method of commercial and corporate printing, where ink is picked up by a metal or paper plate, passed to an offset drum, and then passed to the paper.
<b>online</b>	Devices under the direct control of a central processing unit, for example a printing system in interactive communication with a mainframe. See also <i>offline</i> .
<b>operating system</b>	Basic host- or LPS-resident controlling program that governs the operations of a computer, such as job entry, input/output, and data management. The operating system is always running when the computer is active. Unlike other types of programs, it does not run to an end point and stop. The operating system of a Xerox LPS is referred to as the operating system software (OSS).
<b>operation</b>	Well-defined action that, when applied to any permissible combination of known entities, produces a new entity.
<b>operator</b>	<ol style="list-style-type: none"><li>1. Part of a process description that indicates the action to be performed on an operand. For example, ADD is an operator that uses two operands (in this case numbers) and produces a third.</li><li>2. Person who operates a device.</li></ol>
<b>operator area</b>	The 24-inch exclusive clearance that must be available directly in front of each component of an LPS for operator activities.
<b>operator command</b>	Statement to control a program, issued through a console device, PC UI, or terminal, causing a control program to provide requested information, alter normal operations, initiate new operations, or terminate existing operations.
<b>orientation</b>	<ol style="list-style-type: none"><li>1. In reference to image area, orientation describes whether the printed lines are parallel to the long edge of the paper or the short edge of the paper.</li><li>2. Choice of printing portrait (vertically) or landscape (horizontally).</li></ol>

---

<b>origin</b>	In reference to image area, this is the upper left corner of a sheet.
<b>output</b>	1. Material produced by a peripheral device of a computer, such as a printout or a magnetic tape. 2. Result of completed operations.
<b>page</b>	1. In computer programming, a block of instruction, data, or both that can be located in main or auxiliary storage. 2. In word processing, a defined section of a document.
<b>page end</b>	Command character (form feed) to terminate the current page.
<b>page orientation</b>	Direction in which data is printed on a report. See also <i>landscape page orientation</i> ; <i>portrait page orientation</i> .
<b>pagination</b>	Process of separating text into pages.
<b>parameter</b>	Part of a command, other than the keyword. See also <i>keyword</i> ; <i>operator command</i> .
<b>password</b>	Unique word or set of characters that an operator or user must supply to log on to a system.
<b>patch</b>	In programming, to modify a portion of the program at the machine language level, as opposed to modifying at the source program level.
<b>PC UI</b>	PC user interface. The PC hardware and Xerox-supplied software which allows the operator to control the LPS by means of a mouse, windows, and icons. See also <i>object mode</i> ; <i>TEM</i> .
<b>PDL</b>	print description language. Language used to describe printing jobs to an LPS. PDL describes the input (type, format, characteristics), performs the processing functions (logical processing), and describes the output (type, format, font selection, accounting options).
<b>physical page</b>	Sheet of paper on which printing is done. See also <i>edgemarking</i> .
<b>pitch</b>	1. Horizontal character spacing; 10-pitch (10 characters per inch) spacing is called pica, and 12-pitch (12 characters per inch) spacing is called elite. 2. The number of page images placed on the xerographic belt during one revolution. The 4635 LPS operates in a multi-pitch mode, allowing the mode to be adjusted according to the width of the paper used.

<b>pixel</b>	Acronym for picture element. Smallest addressable point of a bit-mapped screen that can be independently assigned color and intensity. Pixels are definable locations on a display used to form images. For graphic displays, more pixels generally provide higher resolution. Spots, dots, and pixels are used interchangeably.
<b>point</b>	Unit of measurement equal to 0.0139 inch. Points are always used to express type size and leading. There are 12 points to a pica and about 72 points to every inch.
<b>point size</b>	Height of character set from the top of its ascenders to the bottom of its descenders in units (points). Point size does not always include leading.
<b>portrait page orientation</b>	Orientation of print lines or the top of an illustration parallel to the short edge of the paper if the sheet is within the standard size range. Sheets larger than standard have the reverse print orientation.
<b>printer</b>	Output device that produces hardcopy printouts. Also referred to as the IOT.
<b>print file</b>	Position of the system disk memory (up to 4 MB) reserved for temporary storage of formatted pages for printing. Pages are retained until they are delivered to the output tray.
<b>printout</b>	Informal expression referring to almost anything printed by a computer peripheral device.
<b>process</b>	1. To perform a systematic sequence of operations, such as add, edit, delete. 2. To produce a specific result by manipulating data.
<b>processor</b>	Applies to any system that is capable of receiving and performing operations upon data and supplying the results of those operations.
<b>program</b>	Complete set of instructions in language compatible with the device to be used. A program directs a system to perform each operation at the right time in the proper sequence.
<b>programmer</b>	Person involved in designing, writing, and testing computer programs.
<b>prompt</b>	Message or symbol displayed on a system console requiring the operator to take action.
<b>proportional font</b>	Font containing characters that vary in width. See also <i>fixed font</i> .

---

<b>proportional spacing</b>	Text in which each alphanumeric character is given a weighted amount of space. Such output has print-like appearance. Proportional spacing allows more space for wide characters and less space for narrow characters.
<b>proportional type</b>	Characters that vary in width.
<b>protocol</b>	Formal set of conventions governing the format of data and the control of information exchange between two communication devices.
<b>purge</b>	To delete data from a system.
<b>queue</b>	List of documents waiting to be processed.
<b>RAM</b>	random access memory. Storage that allows data, such as documents, to be stored and retrieved directly by address location without reading through any other data.
<b>raster data</b>	Binary data, usually consisting of dots arranged in scan lines, according to the print order.
<b>rasterization</b>	Creation of a page's bit map image for printing.
<b>read/write head</b>	Input/output device that reads and writes data in the form of magnetic dots on the surface of an external storage medium, such as a magnetic disk.
<b>record</b>	Collection of data or words treated as a unit.
<b>recovery</b>	Act of overcoming a problem or error during processing. Typically, a specialized software recovery routine gains control and attempts to resolve the error without crashing the system.
<b>remote access</b>	Access to a central computer by terminals or devices geographically separated from that computer.
<b>replace</b>	Process of exchanging one portion of text for another. This process encompasses two functions: deleting old text and inserting new.
<b>report</b>	In setting a separation boundary through the Bin Full Criteria task, report refers to a subset of a job (a job may consist of one or more reports).
<b>resolution</b>	Number of dots per unit. The LPS imaging system converts a character from digitized data into a printed image composed of these tiny dots. The greater the number of dots per inch, that is, the resolution, the clearer the image that is produced.

<b>RIP</b>	raster image processor. LPS option that supports the Interpress V3.0 Publications Set.
<b>ROM</b>	read-only memory. Solid-state memory for programs. It cannot be rewritten.
<b>run</b>	Single continuous execution of a program by a system.
<b>save</b>	To store programs, data, or text for retrieval at a later time.
<b>scale</b>	To adjust font or image size according to given proportions.
<b>scroll</b>	Manipulation of a display to bring upper or lower portions of a document page into view when no space is available for the entire document at once.
<b>scroll bar</b>	Part of a window that allows you to view information extending beyond the window display.
<b>SCSI</b>	small computer system interface. Accepted standard for connecting peripheral devices to computers.
<b>secondary storage</b>	Form of storage external to a system, such as magnetic tapes or floppy disks.
<b>security</b>	1. Procedure for limiting access to the system resources, programs, or files, to authorized personnel. 2. Protecting programs and files from unintentional or undesired modification.
<b>SEF</b>	short-edge feed. The movement of paper through the printer in the direction of the paper width (the shorter side of a sheet of paper). For the 4635 LPS, short-edge feed allows larger sizes of paper (up to 11 by 17 inches/279 by 432 mm) to be printed.
<b>set</b>	In setting a separation boundary through the Bin Full Criteria task, set refers to multiple copies of the same report.
<b>simplex printing</b>	Printing on one side of the page. See also <i>duplex printing</i> .
<b>SNA</b>	System Network Architecture. Total description of logical structure, formats, and protocols of operation sequences for transmitting an information unit through the communication system. Developed by IBM for distributed processing networks.
<b>software</b>	Programs, including operating systems, procedures, utilities, and applications programs, written for a system. Software can be supplied by the hardware manufacturer or other firms but does not include programs written by the user.
<b>sort</b>	To rearrange data records according to a particular item (field) which they all contain, using a predetermined ordering scheme.



---

<b>source</b>	Terminal node at which data enters a network. For example, a computer transmitting data through telecommunication lines to several other computers or receiving terminals.
<b>source file</b>	File containing source language statements or commands.
<b>source language</b>	Language, high-level or low-level, used by a programmer. A source language must be converted by a compiler to machine language for the instructions to be executed.
<b>source program</b>	Program written in source language.
<b>space</b>	Blank area between words, recognized as a character by word and data processing systems.
<b>special processing</b>	Commands allowing the user to process special reports, such as printing certain records, or printing on special paper.
<b>spooling</b>	Process of releasing data from main memory and storing it temporarily until a peripheral device is ready to accept it, for example storing text before sending it to a printer.
<b>spot</b>	Unit of measurement representing a fraction of an inch, for example, 300 spots per inch (spi). May also be referred to as a picture element (pixel) or dot.
<b>statement</b>	Detailed written instructions in a program step. A statement is written according to specific rules called syntax.
<b>station</b>	1. In data communications, a terminal device connected to a data link. 2. In computer networks, any of the numerous terminal devices that form a network.
<b>stock</b>	User-defined name in the JSL that specifies a certain type of paper for printing a job.
<b>stockset</b>	Collection of stocks to be used on a print job. See also <i>stock</i> .
<b>storage</b>	Retention of information. Primary storage refers to internal storage where data and program instructions pertinent to current operations/jobs are held. Auxiliary storage refers to external media, such as disks or tapes, for use at a later time.
<b>string</b>	Connected sequence of alphanumeric characters treated as one unit of data by a program.
<b>symbol</b>	Character used in a computer language to specify a particular function.
<b>synchronous</b>	Efficient encoding of data suitable for high-speed, block-oriented data transmission by using equal time elements.

<b>syntax</b>	Rules governing the structure of expressions in a programming language.
<b>syntax error</b>	System response to a mistake in a command entry.
<b>system</b>	1. In data processing, a collection of parts and procedures organized to accomplish a set of specific functions. 2. Assembly of components united by some form of regulated interaction to form an organized whole. 3. Operations or procedures through which a business activity is accomplished.
<b>system controller</b>	Part of the LPS that provides interfacing capability, data handling, formatting, buffering, and operator control for the system. Also referred to as the "ESS."
<b>system disk</b>	Magnetic disk storage medium, usually of large capacity, that is not removable as opposed to floppy disk or disk packs.
<b>system file</b>	Master software program that keeps all components working together.
<b>system generation</b>	Process whereby the system is made ready to operate. Typically involves selecting the operative parameters and activating the relevant software.
<b>system page</b>	Maximum area in which text and graphics can be imaged on a printing system.
<b>system software</b>	Software programs that support and/or control system functions by governing hardware operation and input/output processes, interpreting source programs and breaking them down into machine language, distributing tasks among various processors, and so on.
<b>systems specialist</b>	The person(s) at a customer site responsible for software, applications, and programming issues.
<b>tab</b>	To move the cursor on a display or printer to a prespecified column on the display or paper, most often by using the <TAB> key on a keyboard.
<b>tape</b>	Recording media for data or computer programs. Tape can be in permanent form, such as perforated paper tape. Generally, tape is used as a mass storage medium in magnetic form and has a far higher storage capacity than disk storage, but it takes longer to write or recover data from tape than from disk.
<b>tape density</b>	The number of characters that can be stored on magnetic media, such as how close together data can be recorded. The Xerox LPS may use either 1600 bpi or 6250 bpi density magnetic media.

---

<b>tape drive</b>	Input/output device that controls the movement of magnetic storage tape past the read/write head while data is accessed or stored.
<b>task</b>	1. Any major job performed by a computer. 2. One of several programs being executed by a system.
<b>telecommunications</b>	Voice or data communications transmitted and received through telephone lines.
<b>teleprocessing</b>	Sending and receiving data through telecommunication lines for processing among various remote terminals and the central processing unit (CPU).
<b>TEM</b>	terminal emulation mode. The processing method of the PC UI which features a character display and the operator's use of the keyboard. The mouse, windows, and icons are inactive in this mode. The PC UI operates in either the TEM mode or in the object mode. See also <i>object mode</i> .
<b>temporary storage</b>	Main memory locations reserved for intermediate results of processing, control values, or other information which need to be kept on hand as a program proceeds.
<b>terminal</b>	Device equipped with a keyboard and connected to a computer or a network.
<b>testing</b>	1. Process of running a program for the express purpose of discovering any errors it may contain. 2. For computer-oriented systems, the process of verifying a system's ability to meet performance objectives in a simulated environment or validating its actual performance in a live environment.
<b>text</b>	In communications, the content portion of a transmitted message.
<b>text string</b>	Consecutive series of characters to be printed exactly as specified in a command.
<b>throughput</b>	In data processing systems, the amount of data that can be processed, transmitted, printed, and so on, per a specified unit of time.
<b>toggle</b>	To switch (alternate) from one tray to another. The system switches from an active feeder or stacker tray to an inactive one to allow continuous printing when the proper commands are invoked.
<b>track</b>	Unit of storage space on a data storage medium, such as a disk. All information stored in a track can be retrieved or recorded in one positioning of a read/write head.

<b>translation</b>	1. In data communications, the conversion of one code to another on a character-by-character basis. 2. In programming, the function of a language processor which converts a source program from one programming language to another.
<b>transmission speed</b>	In data communications, the rate at which data is passed through communication lines, usually measured in bits per inch (bpi).
<b>transmit</b>	To send data from one place to another.
<b>turnaround time</b>	1. In data processing, the time elapsed between submission of a job for processing and the turnaround for results. 2. In communications, the time required to convert a device from receiving mode to its sending mode or vice versa.
<b>two-up</b>	Application that prints two logical pages on one side of a physical page.
<b>typeface</b>	1. All type of a single design. 2. Set of characters with design features that make them similar to one another.
<b>type size</b>	Height of a typeface, measured from the bottom of its descenders to the top of its ascenders, expressed in points.
<b>type style</b>	Italic, condensed, bold, and other variations of typeface that form a type family.
<b>UCS</b>	Universal Character Set. Printer feature that permits the use of a variety of character arrays.
<b>upload</b>	To copy files from a remote peripheral device to a host. LPS files are not copied to the host because one of the LPS functions is to store files for the host.
<b>utility program</b>	General-purpose program that performs activities, such as initializing a disk or sorting, which are not specific to any application.
<b>validation</b>	Process of testing a system's ability to meet performance objectives by measuring and monitoring its performance in a live environment.
<b>variable</b>	Information of a changeable nature which is merged with a standard or a repetitive document to create specialized or personalized versions of that document.
<b>variable data</b>	Variable data is not a part of a form design. It varies from page to page.
<b>variable text</b>	Text of changing nature, such as various names and addresses combined with a form letter to make a complete document.

---

<b>verification</b>	Process of testing a system's ability to meet performance objectives by running programs in a simulated environment.
<b>virtual page</b>	Page area selected by a forms designer for printing.
<b>warning message</b>	System-issued message indicating that an error has been encountered even though the program has not failed.
<b>weight</b>	Characteristic of type determined by how light or dark it appears.
<b>window</b>	In the PC UI, the graphic display object that allows you to select options and enter information.
<b>write</b>	To record data in memory or an external storage medium.
<b>write protection</b>	Data protection feature implemented on magnetic media (for example floppy disk, 9-track tape) to prevent stored data from being modified, written over, or erased.
<b>x axis</b>	Horizontal axis on a forms grid.
<b>x dot</b>	Unit of measurement representing a fraction of an inch. It may also be referred to as a picture element (pixel) or spot, for example, 1/600 spots per inch (spi).
<b>xerographic engine</b>	Component of a printer that develops an image, transfers it to paper, and fuses it for output as hardcopy.
<b>x height</b>	Height of lowercase letters without their ascenders or descenders (height of letter "x").
<b>y axis</b>	Vertical axis on a forms grid.

---

## Acronyms

---

<b>ACT</b>	Advanced Customer Training
<b>ANSI</b>	American National Standards Institute
<b>ASCII</b>	American Standard Code for Information Interchange
<b>BCD</b>	binary coded decimal
<b>bpi</b>	bits per inch
<b>bps</b>	bits per second
<b>BSC</b>	binary synchronous communications
<b>CD</b>	character dispatcher
<b>CDC</b>	control data communications
<b>CD/IG</b>	character dispatcher/image generator
<b>CM</b>	control module
<b>CME</b>	copy modification entry
<b>cpi</b>	characters per inch
<b>CPU</b>	central processing unit
<b>CR</b>	carriage return
<b>CSR</b>	customer support representative
<b>DC</b>	data center
<b>DCE</b>	data communications equipment
<b>DDCMP</b>	Digital Data Communication Message Protocol
<b>DEC</b>	Digital Equipment Corporation
<b>DFA</b>	Document Feeding and Finishing Architecture
<b>DJDE</b>	dynamic job descriptor entry

---

<b>DMA</b>	direct memory access
<b>DOS</b>	disk operating system
<b>dpi</b>	dots per inch
<b>DSDD</b>	double sided double density
<b>DSR</b>	disk save and restore
<b>DSSD</b>	double sided single density
<b>EBCDIC</b>	extended binary coded decimal interchange code
<b>ECMA</b>	European Computer Manufacturers Association
<b>ENET</b>	Ethernet network
<b>ESS</b>	electronic subsystem, also referred to as the system controller
<b>FCG</b>	finishing configuration utility
<b>FCP</b>	file control parameter
<b>FDL</b>	forms description language
<b>FDR</b>	file directory
<b>FMS</b>	file management subsystem
<b>FPS</b>	formatting print service
<b>FSL</b>	forms source library
<b>GIS</b>	graphic input station
<b>gsm</b>	grams per square meter
<b>GVG</b>	graphics video generator
<b>HCF</b>	high-capacity feeder
<b>HCS</b>	high-capacity stacker
<b>HFDL</b>	host forms description language

<b>HIP</b>	Host Interface Processor
<b>hpos</b>	horizontal positioning
<b>IBM</b>	International Business Machines Corporation
<b>IFU</b>	Interpress font utility
<b>IG</b>	image generator
<b>IGM</b>	image generator module
<b>I/O</b>	input/output
<b>IOM</b>	image output module
<b>IOT</b>	input output terminal, also referred to as "printer"
<b>IPD</b>	Interpress decomposer
<b>IPFONTS</b>	Interpress fonts
<b>IPM</b>	Interpress mapping
<b>ips</b>	inches per second
<b>JCB</b>	job control block
<b>JCL</b>	job control language
<b>JDE</b>	job descriptor entry
<b>JDL</b>	job descriptor library
<b>JSL</b>	job source library
<b>LAN</b>	local area network
<b>laser</b>	light amplification by stimulated emission of radiation
<b>LED</b>	light-emitting diode
<b>LEF</b>	long-edge feed
<b>LF</b>	line feed character



---

<b>Ipi</b>	lines per inch
<b>LPS</b>	Laser Printing System
<b>MTU</b>	magnetic tape unit (refers to the 9-track magnetic tape drive; also referred to as "magnetic tape drive")
<b>MICR</b>	Magnetic Ink Character Recognition
<b>OLI</b>	online interface
<b>OS</b>	operating system
<b>OSDS</b>	operating system diagnostic software
<b>OSEXEC</b>	operating system executive
<b>OSS</b>	operating system software
<b>PC</b>	personal computer
<b>PCC</b>	printer carriage control
<b>PCUI</b>	personal computer user interface
<b>PDL</b>	print description language
<b>PE</b>	phase encoded
<b>ppm</b>	pages per minute
<b>PQA</b>	print quality adjustment
<b>PROM</b>	programmable read-only memory
<b>PSC</b>	printer subsystem controller
<b>pt</b>	point
<b>PWBA</b>	printed wiring board assembly
<b>QIC</b>	1/4 inch cartridge
<b>RAM</b>	random access memory
<b>RIP</b>	raster image processor

<b>ROS</b>	raster output scanner
<b>RTC</b>	real time clock
<b>SAFES</b>	stand-alone field engineering software
<b>SAN</b>	software analysis number
<b>sci</b>	START command index
<b>SCSI</b>	small computer system interface
<b>SDLC</b>	synchronous data link control
<b>SEF</b>	short-edge feed
<b>SFS</b>	status file services
<b>SIF</b>	sequence insert file
<b>SNA</b>	system network architecture
<b>spi</b>	spots per inch
<b>SST</b>	system software tape
<b>sysgen</b>	system generation
<b>TL/DL</b>	text line/display list
<b>UCS</b>	Universal Character Se
<b>UCSB</b>	Universal Character Set Buffer
<b>UI</b>	user interface
<b>VM</b>	virtual memory
<b>vpos</b>	vertical positioning
<b>VS</b>	virtual storage
<b>WAN</b>	wide area network
<b>XCSC</b>	Xerox Customer Support Center

<b>XDGI</b>	Xerox DCF and GDDM Interface
<b>XDSS</b>	Xerox Documentation and Software Services
<b>XMP</b>	xerographic mode persistence
<b>XMS</b>	xerographic mode switching
<b>XNS</b>	Xerox Network Systems
<b>XPAF,XPF</b>	Xerox Printer Access Facility
<b>XPMF-VMS</b>	Xerox Print Management Facility - VMS Version
<b>XPPI</b>	Xerox Pen Plotter Interface



## Numerals

.25-inch cartridge tape, 1-2 to 1-3  
7X10 enablement kit, 2-4  
9-track magnetic tape, 2-2  
18-track cartridge tape drive, 2-2  
3480 data format, 2-2  
7650 Pro Imager scanner, 2-7

## A

access requirements, delivery, 3-12 to 3-14  
Advanced Customer Training (ACT), xiii, 3-22  
altitude limitation, 3-15  
ANSI-compatible 0.5 inch tape, 2-2  
applications, identifying new, 5-5  
attention  
    alarm, 1-5  
    light, 1-5

## B

bar code device, 2-4  
base components  
    printer, 1-4 to 1-5  
    system controller, 1-2 to 1-4  
boot switch, 1-4  
bypass transport, 2-3 to 2-4, 3-7, 3-21

## C

cable  
    enter/exit locations, 3-11  
    lengths, 3-10 to 3-11  
cartridge tape, 3-25  
channel-attached interface, 3-21  
checklist  
    installation planning, xv to xvi  
    supplies, 5-11  
clearance, see *equipment dimensions*;  
    *space planning*  
components, 1-2 to 1-5  
consumable supplies listing, 5-6 to 5-10  
control  
    console, 1-5  
    panel, printer, 1-4  
customer  
    education, 3-22 to 3-23  
    responsibilities, xiii, 4-2  
    service support, 5-1 to 5-2  
    training, xiii, 3-22 to 3-23

## D

data cables, 3-10

## delivery

access requirements, 3-12 to 3-14  
turning radius, 3-12 to 3-13  
see also *installation*

developer, 3-25

dimensions, equipment, 3-2 to 3-6

## disk

floppy, 2-3  
system, 2-3

dry ink, 3-25

## E

### electrical

cables, 3-10 to 3-11  
requirements, 3-15 to 3-20

enhanced graphics ink and font memory (EGIFM), 2-3

environmental requirements, 3-15 to 3-20

equipment dimensions, 3-2 to 3-6

Ethernet (XNS), 2-2

expanded system disk memory, 2-3

## F

### feeder

requirements  
    power, 3-21  
    space, 3-7 to 3-9  
stacker, 1-4 to 1-5, 2-3  
trays, 1-4 to 1-5

finishers, 3-7 to 3-9, 3-21

floppy disk drive, 2-3

Font Center, 3-23 to 3-24, 5-3

### fonts

memory, 2-3  
ordering, 5-3  
types, 3-23 to 3-24

fuser agent, 3-25

## G

### graphics

memory, 2-3  
scanner, 2-7

grid pattern, 3-30

## H

### hardware

components, 1-2 to 1-5  
options, 2-1 to 2-4

heat dissipation, 3-15

### high-capacity

feeder, 1-5  
stacker, 1-5

- HIP interfaces
  - XNS, 2-2
  - XPAF, 2-2
  - XPSM, 2-3
- Host Forms Description Language (HFDL), 2-8
- humidity, 3-15
- I**
- input enablement device, 2-4, 3-21
- installation
  - planning checklist, xiv to xvi
  - process, 4-1
  - responsibilities
    - customer, xiii, 4-2
    - Xerox, xii to xiii, 4-1 to 4-2
  - see also *delivery*
- interfaces
  - HIP, 2-2 to 2-3
  - offline, 1-2 to 1-3, 2-1 to 2-2
  - online, 2-1
  - requirements
    - channel-attached, 3-21
    - third party, 3-21
  - switchable, 2-1
- inverter-feeder/stacker, 1-4 to 1-5
- L**
- layout, efficient, 3-11 to 3-12
- M**
- Magnetic Ink Character Recognition, see *MICR*
- maintenance, 5-5
- memory options, 2-3
- meter
  - reading, 5-5
  - reporting, 5-5
- MICR, 1-6
- N**
- new applications, identifying, 5-5
- O**
- offline interfaces, 1-2 to 1-3, 2-1 to 2-2
- online interfaces
  - cable requirements, 3-21
  - host systems, 2-1
- operator
  - control panel, 1-4
  - tasks, 5-5
  - training, xiii, 3-22 to 3-23
- options
  - graphics, 2-7
  - host-resident software, 2-8
  - memory, 2-3
  - printer, 2-3 to 2-4
  - system controller, 2-1 to 2-3
- ordering supplies, 3-23 to 3-25, 5-6 to 5-10
- outlets, electrical, 3-16 to 3-21
- P**
- paper specifications, 3-24 to 3-25
- PC User Interface (PC UI), 1-2 to 1-3
- peripheral cabinet, 2-2, 3-2 to 3-3, 3-10 to 3-11
- personnel, xiii to xiv
- planning checklist, installation, xv to xvi
- postinstallation, 5-1 to 5-11
- power
  - cables, 3-11
  - cord configuration, 3-20
  - receptacle requirements, 3-16 to 3-19
- printer
  - cables, 3-10 to 3-11
  - clearance, 3-7 to 3-10
  - components, 1-4 to 1-5
  - configurations, 2-5 to 2-6
  - control console, 1-5
  - dimensions, 3-2 to 3-6
  - electrical requirements, 3-15 to 3-20
  - operator control panel, 1-4
  - space, planning, 3-27 to 3-30
  - trays, 1-4 to 1-5
  - turning radius, 3-12 to 3-14
- processor feeder trays, 1-4 to 1-5
- publications, related, iii
- purge tray, 1-4 to 1-5
- Q**
- QIC, 1-2 to 1-3
- R**
- Raster Image Processor (RIP), 2-7
- requirements, operating space, 3-7 to 3-10
- responsibilities
  - customer, xiii, 4-2
  - Xerox, xii to xiii, 4-1 to 4-2
- routine maintenance, 5-5
- S**
- sample tray, 1-4 to 1-5
- scanner, 2-7
- service, xiii, 5-1 to 5-4
- shared space, 3-7 to 3-10
- site selection, xii
- software
  - host-resident packages, 2-8
  - kits, 4-2
- space planning
  - cable
    - enter/exit locations, 3-11
    - lengths, 3-10 to 3-11
  - clearance, 3-7 to 3-9
  - efficiency, 3-11 to 3-12
  - grid pattern, 3-30
  - shared space, 3-7 to 3-9
  - templates, 3-27 to 3-29
- status
  - codes, 5-2
  - messages, 5-2
- storing paper, 3-25
- supplies
  - checklist, 5-11
  - consumables table, 5-6 to 5-10
  - developer, 3-25
  - dry ink, 3-25

- fonts, 3-23
- ordering, 3-24 to 3-25
- paper, 3-24 to 3-25
- Xerox
  - Parts Marketing Center, 5-4 to 5-5
  - Supplies Order Service, 5-4
- switchable interface configuration, 2-1
- system controller
  - components, 1-2 to 1-4
  - control panel, 1-4
  - dimensions, 3-2
  - interface
    - HIP, 2-2 to 2-3
    - offline, 2-1 to 2-2
    - online, 2-1
  - memory options, 2-3
  - PC UI, 1-3
  - disks, 1-3, 2-3
  - terminal, 1-3
- T**
- tape
  - drives, 1-3, 2-2
  - formats, 3-25
- temperature, operating, 3-6
- templates, space planning, 3-26 to 3-29
- terminal, 1-3
- third party connections, 3-21
- toner, see *dry ink*
- training
  - Advanced Customer Training (ACT), xiii, 3-22
  - LPS workshops, 3-22 to 3-23
  - operator, xiii, 3-22
- turning radius, 3-12 to 3-14
- V**
- vertical clearance, 3-1
- voltage requirements, 3-15 to 3-20
- W**
- workshops, 3-22 to 3-23
- X**
- Xerox
  - 7650 Pro Imager, 2-7
  - Connection, 3-21
  - Customer
    - Documentation Catalog, 5-3
    - Education, 3-25
    - Support Center, 5-1 to 5-2
  - Documentation and Software Services (XDDS), 5-3 to 5-4
  - Font Center, 1-1, 5-3 to 5-4
  - Network Systems (XNS), 2-2
  - Parts Marketing Center, 5-4 to 5-5
  - Pen Plotter Interface, see *XPPI/XDGI*
  - Print Services Manager (XPSM), 2-3
  - Printer Access Facility (XPAF), 2-2, 2-8
  - Supplies Order Service, 5-4 to 5-5
  - support services, xii to xiii, 5-1 to 5-5
- XPPI/XDGI, 2-8

